

INSTALLATION GUIDE

AC6275 Commercial Slip Ring Assembly

Proper Use and Mounting Instructions

Shaft mounted units:

1. Position the slip ring in the desired location and tighten both set screws (10-32 x .625 supplied) to the shaft. Maximum torque 50-60 lb-in (DO NOT OVER TORQUE)
2. Route the wiring and make the necessary connections. Do not allow the stator side wiring to restrict free rotation of the slip ring.
3. Position a 5/16" (max. dia.) screw or pin (NOT SUPPLIED) in the anti-rotation tab to the 3.75" dimension as shown.

CAUTION: Because of possible geometric mismatching between the customer's application and the slip ring, "hard mounting" of both ends of the slip ring (i.e., securing the rotor and stator such that there is NO floating of the stator anti rotation tab during operation) is not recommended and may cause premature failure.

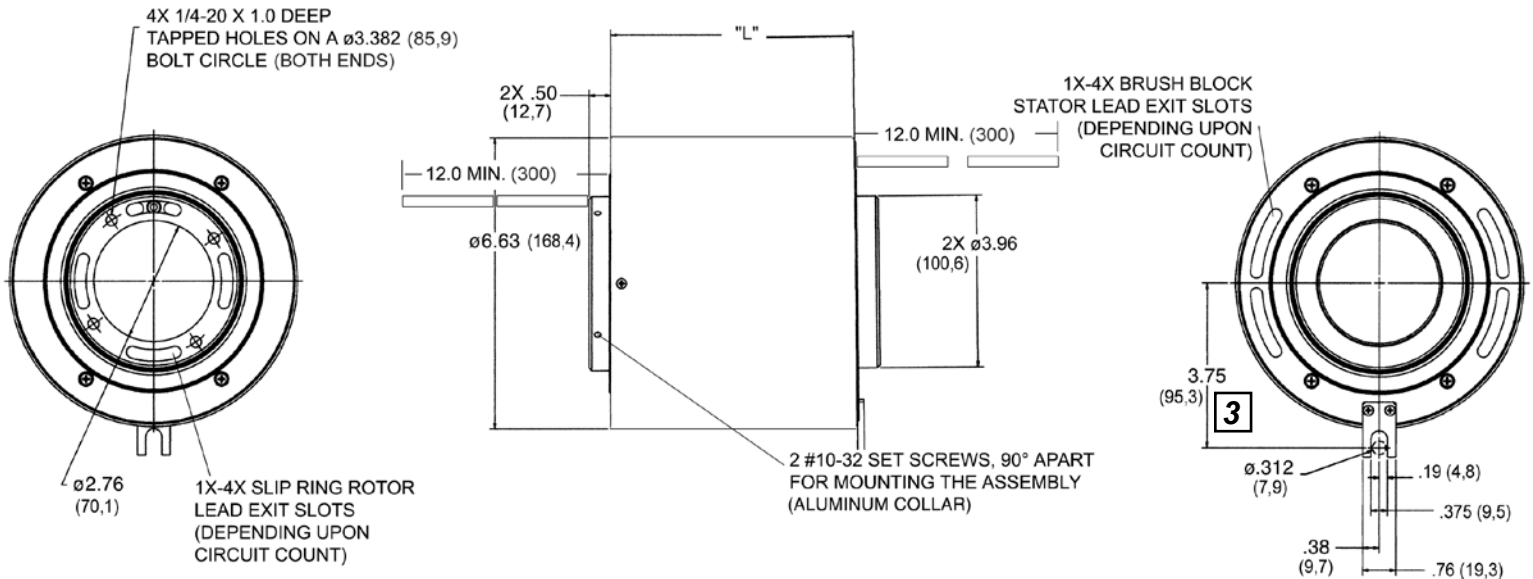

* Dimensions are in inches (millimeters)

Part #	# of Circuits	Housing Length (L)	# of Modules
AC6275-6	6 power ckts max or 36 signal ckts max	6.6" (167,6)	6
AC6275-12	12 power ckts max or 72 signal ckts max	11.2" (284,5)	12
AC6275-18	18 power ckts max or 108 signal ckts max	15.7" (398,8)	18
AC6275-24	24 power ckts max or 144 signal ckts max	20.5" (520,7)	24