

MD6038 – Slip Ring

MD6043 – Brush Block

Miniature slip ring separates with through-bore

Description

A slip ring can be used in any electromechanical system that requires unrestrained, continuous rotation while transferring power and / or data from a stationary to a rotating structure. A slip ring is also called a rotary electrical interface, commutator, collector, swivel or a rotary joint.

Sometimes a self contained “capsule” is not practical due to size constraints or cost limitations, and a “separate” is the solution. The term separate indicates an individual rotor / brush block combination. If a separate rotor / stator approach is best for your application, consider our MD series.

The MD series slip ring separate has 6 circuits and features a 3/8” unobstructed bore through the center that provides routing space for hydraulics, pneumatics, or for a concentric shaft mount.

Features

- 6 circuits
- 3/8 inch unobstructed bore. Other bore sizes also available.
- Gold-on-gold contacts. Provide enhanced conductivity and low noise.
- Excellent signal handling performance. Noise as low as 15 milliohms per circuit pair can be achieved at 60-100 rpm.

Benefits

- Improved system performance. Slip rings can improve mechanical performance, simplify system operation and eliminate damage-prone wires dangling from movable joints.
- Long Life. We use gold on gold contacts to extend unit life to exceed or meet the requirements for most commercial / industrial requirements.

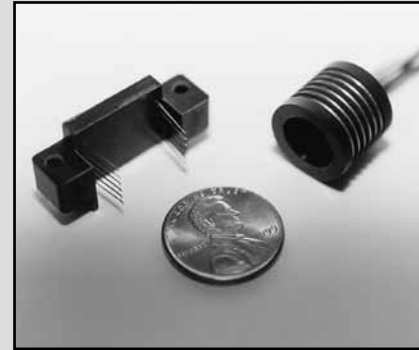

Typical Applications

This separate assembly provides high speed performance and an unobstructed bore-through the center of the unit. It is successfully performing in instrumentation applications where miniaturization is critical, such as:

- Aircraft cockpit instruments
- Sputtering machines for the manufacture of integrated circuits
- Custom machinery
- OEM machinery
- Power tools

Specifications	
Ring O.D.	.550 inch (13,9 mm)
Ring-to-Ring Pitch	.060 inch (1,52 mm)
Bore	.376 inch (9,55 mm)
Volts	240 VDC
Current Rating	2 amps / ckt
Ring Groove Geometry: V-Groove with Raised Barriers	

Lead Wire	Color Codes
Ring #	Color Code
1	BLK
2	BRN
3	RED
4	ORN
5	YEL
6	GRN

Note: For optimal life and performance, ring and brush contact areas should be lubed.

MD6038 Dimensions

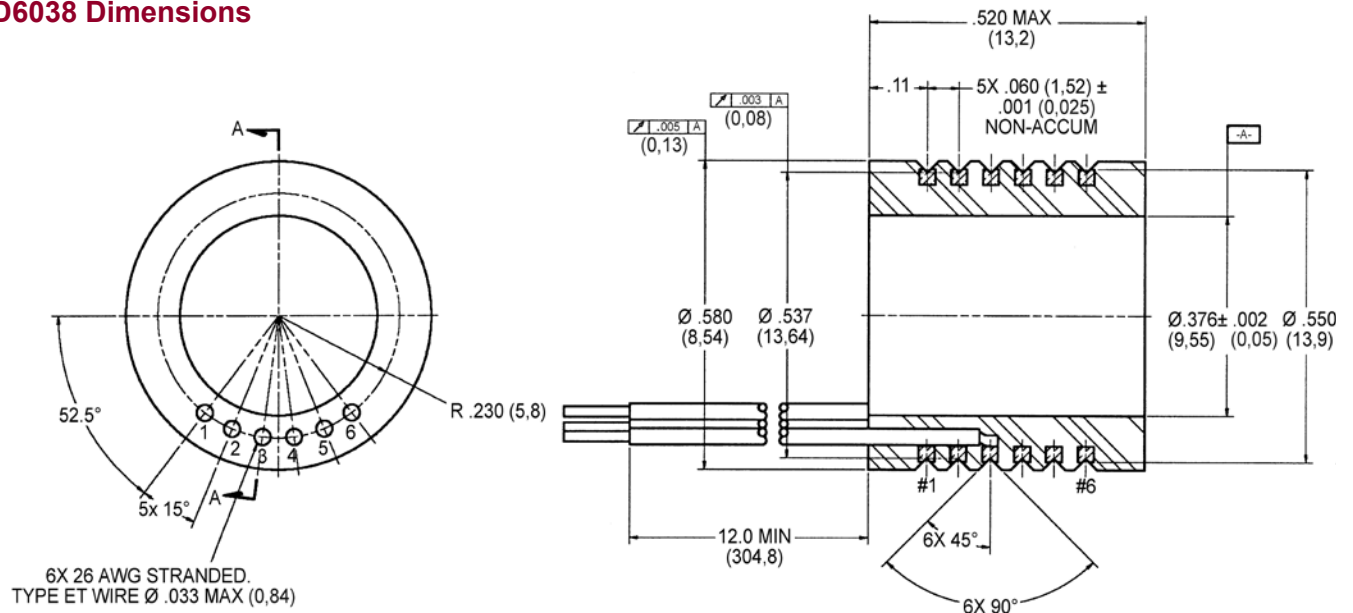

MD6043 Dimensions

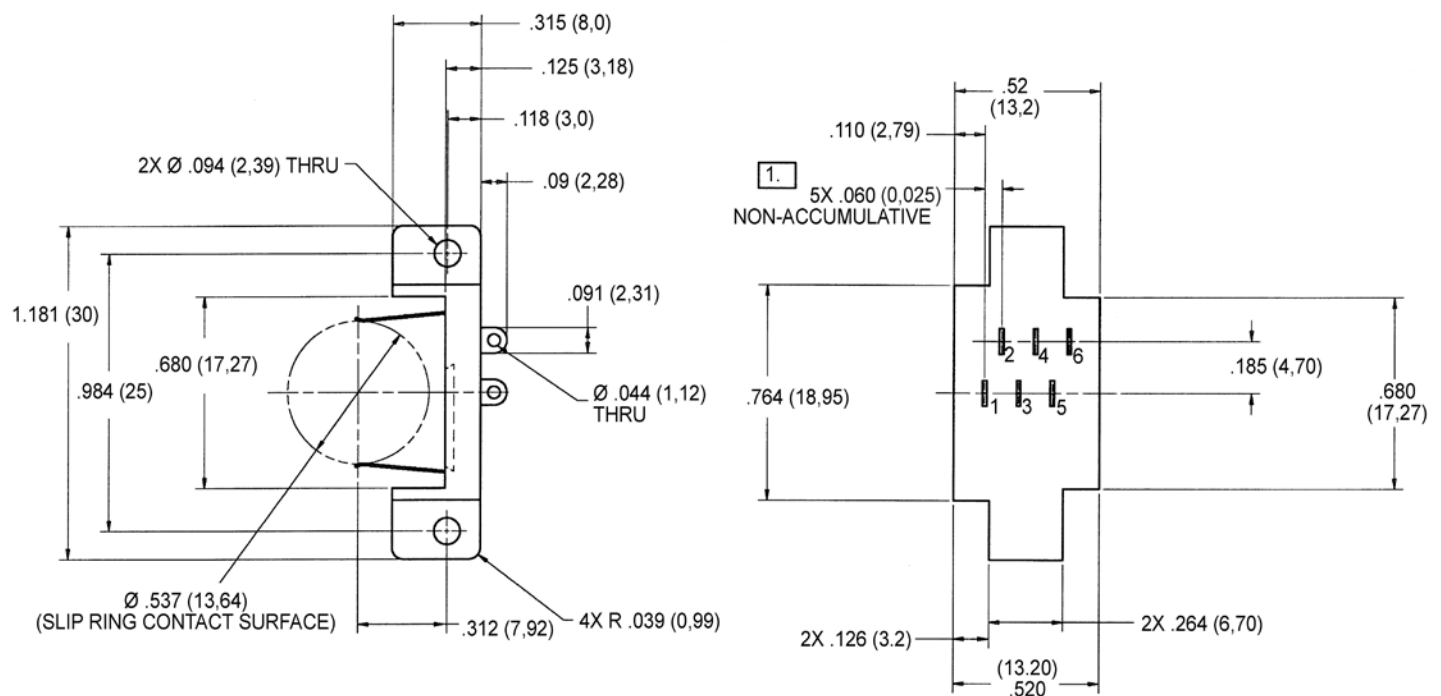

Dimensions in inches (millimeters)