

DIRECT DRIVE SERVOVALVE

70 MPa OPERATING PRESSURE

J634 SERIES

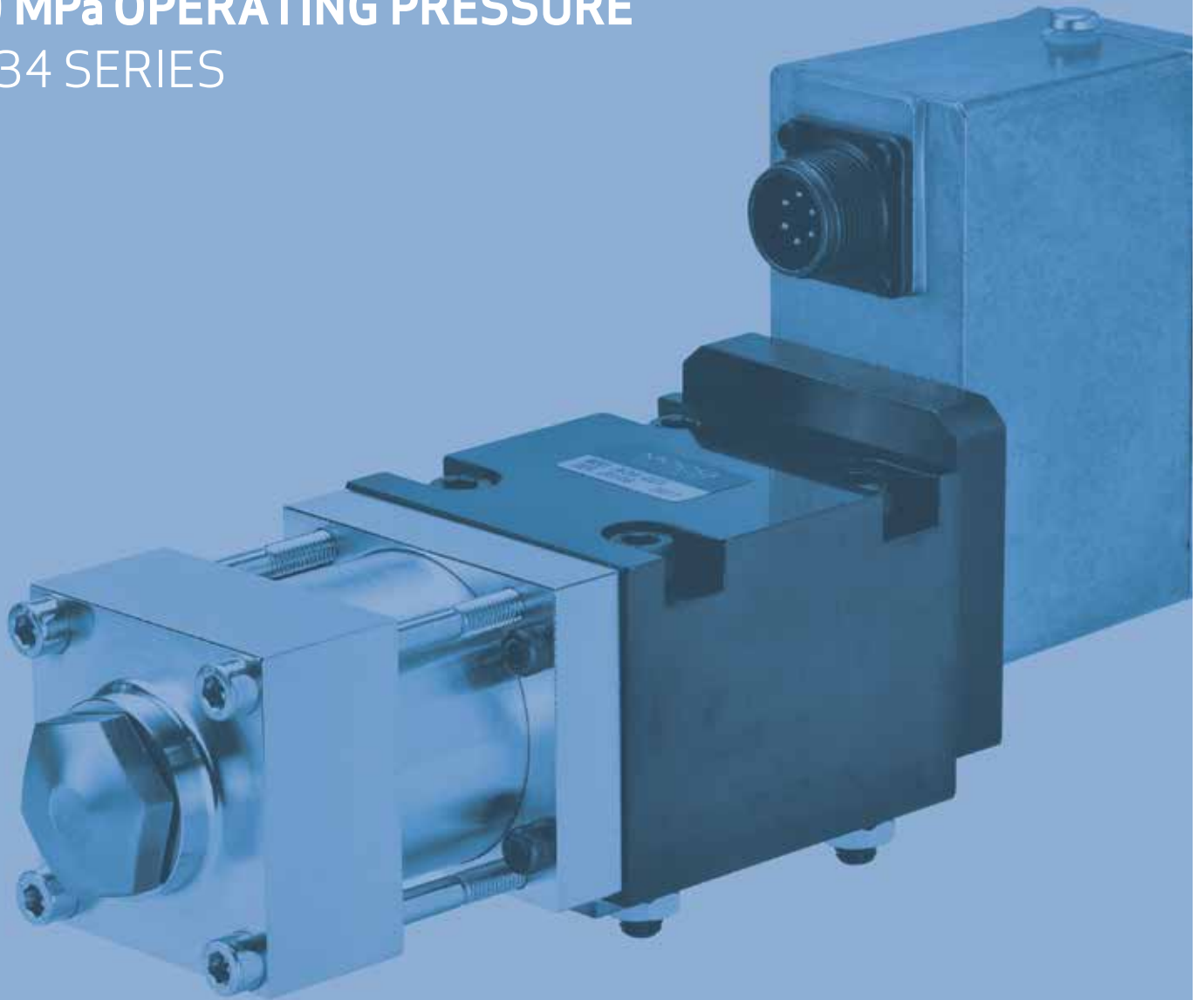

A DIRECT DRIVE SERVOVALVE (DDV) WITH ELECTRONIC CLOSED LOOP CONTROL OF SPOOL POSITION, WITH SPOOL POSITION CONTROL IN BOTH DIRECTIONS, PERMITTING DIRECT CONTROL FROM A MACHINE CONTROLLER WITHOUT ADDITIONAL INTERFACE ELECTRONICS

The series J634 is a direct drive servovalve (DDV) with electronic closed loop control of spool position; suitable for operating pressures up to 70 MPa. The spool is driven by a permanent magnet linear force motor which can actively stroke the spool from its spring centred position in both directions. This is an advantage over proportional solenoids which can only provide force in one direction and at much lower force levels. This permits control of the valve directly from, for example a machine control without the use of additional interface electronics.

TABLE OF CONTENTS

Outline..... 2

Features..... 3

Specifications..... 4

Technical Data..... 5

External view of J634-001X..... 6

External view of J634-010X..... 7



J634 - 010X

Note: The information or details stated in this document is subject to change without notice. Please contact us for the latest information.

FEATURES

- Rated pressure 70 MPa
- Mounting pattern to DIN 24340 / Cetop 5
- High force level permanent magnet linear motor
- No pilot stage oil flow
- At loss of supply voltage, or broken cable, or emergency stop the valve returns to its spring centred, safe null position without an excursion through a load move position.
- Dynamic performance independent of supply pressure.
- IP65 (DIN 40050) degree of protection.
- Low hysteresis and high resolution.
- Improved false polarity protection and over voltage protection.
- Electronic valve null adjust to compensate for load drift.
- Standardised spool position monitoring.

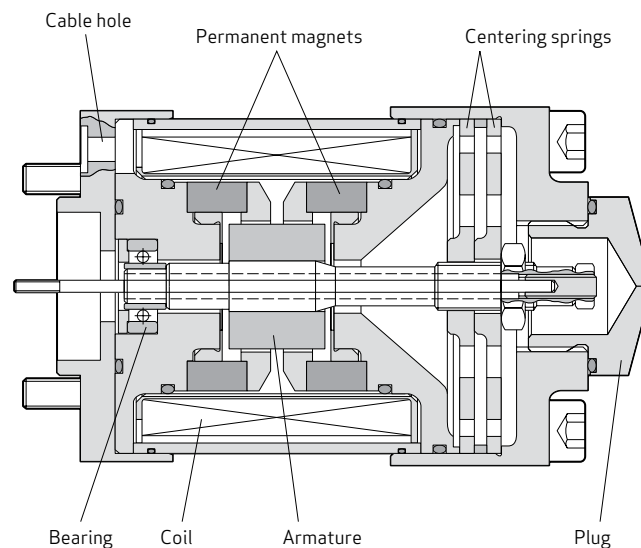
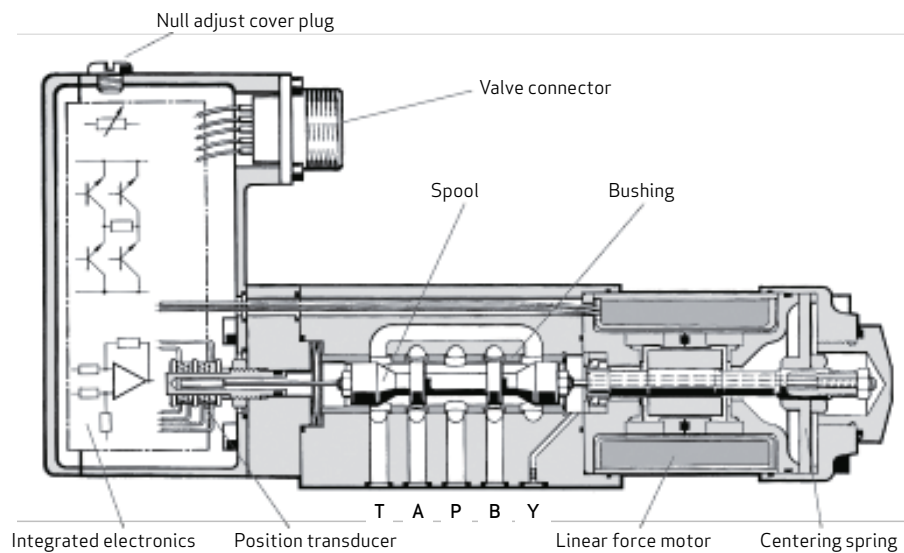

SPECIFICATIONS

Rated Flow	[L/min] 4 way, P=7 MPa	2.5 L/min	5 L/min	7.5 L/min	10 L/min	20 L/min	40 L/min
Mounting pattern		DIN 24340 / ISO4401 Cetop5 (but mounting bolt is M8)					
Valve version		Single Stage, Direct Drive					
Spool Type		Bushing-Spool Type +/- 3 % overlap, Curvilinear flow curve					
Internal Leakage	[L/min] @14 MPa	0.1 L/min	0.1 L/min	0.16 L/min	0.2 L/min	0.4 L/min	0.8 L/min
Power Supply		DC24 V, 1.2 A				DC24 V, 2.2 A	
Rated Signal	Standard	+/-10 V					
	Option 1	+/- 10 mA					
	Option 2	+4~20 mA					
Rated Pressure		70 MPa					
Operating Pressure Range		0~70 MPa					
Y-Port (External)		0~5 MPa					
Spool position	(F terminal)	+4~20 mA					
Polarity		Flow out port A with D(+), E(-)					
Frequency Response		See characteristic curves					
Step Response		See characteristic curves					
Null Shift	with $\Delta T=55\text{ }^{\circ}\text{C}$	$\leq 5.0\%$					
Threshold		$\leq 0.2\%$					
Hysteresis		$\leq 0.5\%$					
Seal Material	Standard	NBR					
	Option	(FKM)					
Operating Fluid Viscosity	Recommended	15~45 mm ² /s					
	Allowable	5~400 mm ² /s					
Temperature Range		-20~+80 °C					
Filter Rating		$\beta_{15}=75$					
Installation Options		Any position, fixed or movable					
Degree of Protection	DIN40050	IP65					
Mass		3.0 kg				6.5 kg	
Port O-rings	P, A, B, T, Y port	Moog P/N A95513-009 (JIS B 2401 1-B P9)					
Mating Electrical Connector		Moog P/N -49054F014S006S (MS3106F-14S-6S)					
Mounting Bolts		Moog P/N A04001-008-055 (JIS B 1176 M8x55L,12.9T)					

TECHNICAL DATA

Typical Characteristic Curves

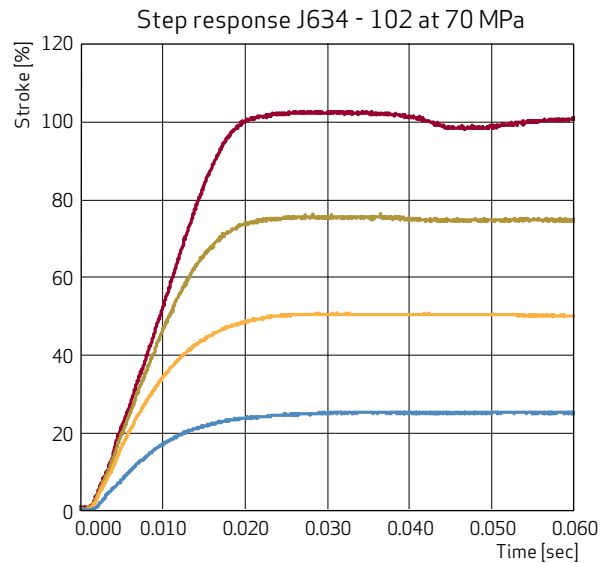
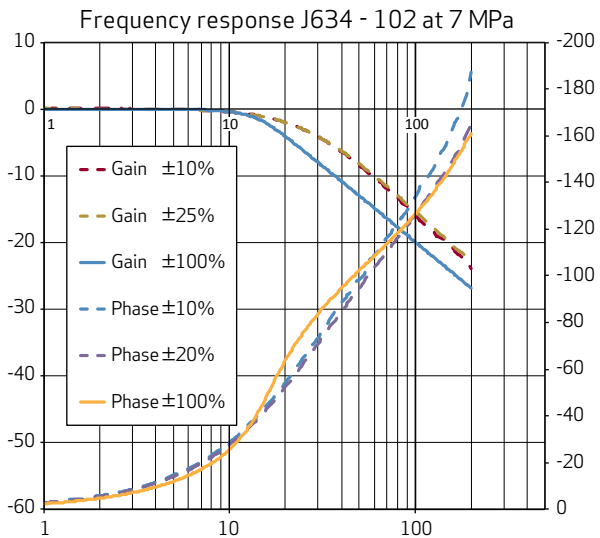
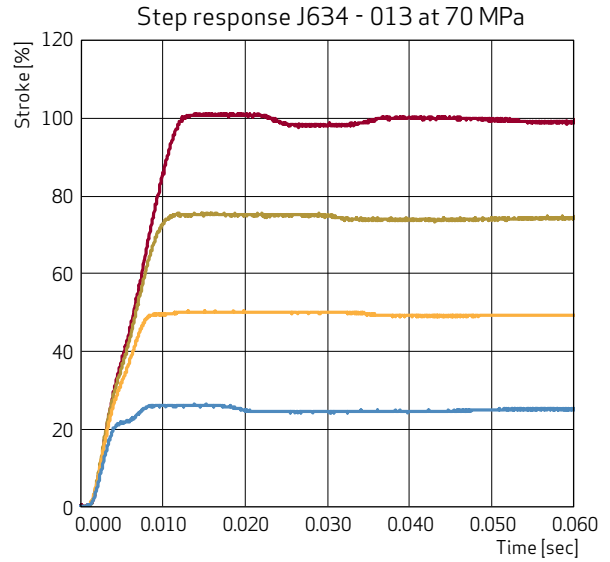
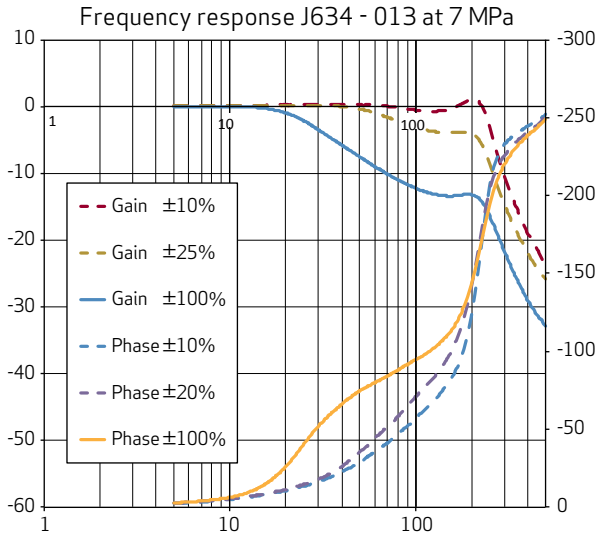

Standard Models

Rated Signal		+/- 10 V	+/- 10 mA	+4~20 mA
Output of Spool Position		+4~20 mA		
Rated Flow [L/min] @ $\Delta P=7$ MPa	2.5 L/min	J634 - 010	J634 - 014	J634 - 018
	5 L/min	J634 - 011	J634 - 015	J634 - 019
	7.5 L/min	J634 - 012	J634 - 016	J634 - 020
	10 L/min	J634 - 013	J634 - 017	J634 - 021
	20 L/min	J634 - 101	J634 - 103	J634 - 105
	40 L/min	J634 - 102	J634 - 104	J634 - 106

Rated Flow 2.5~10 L/min

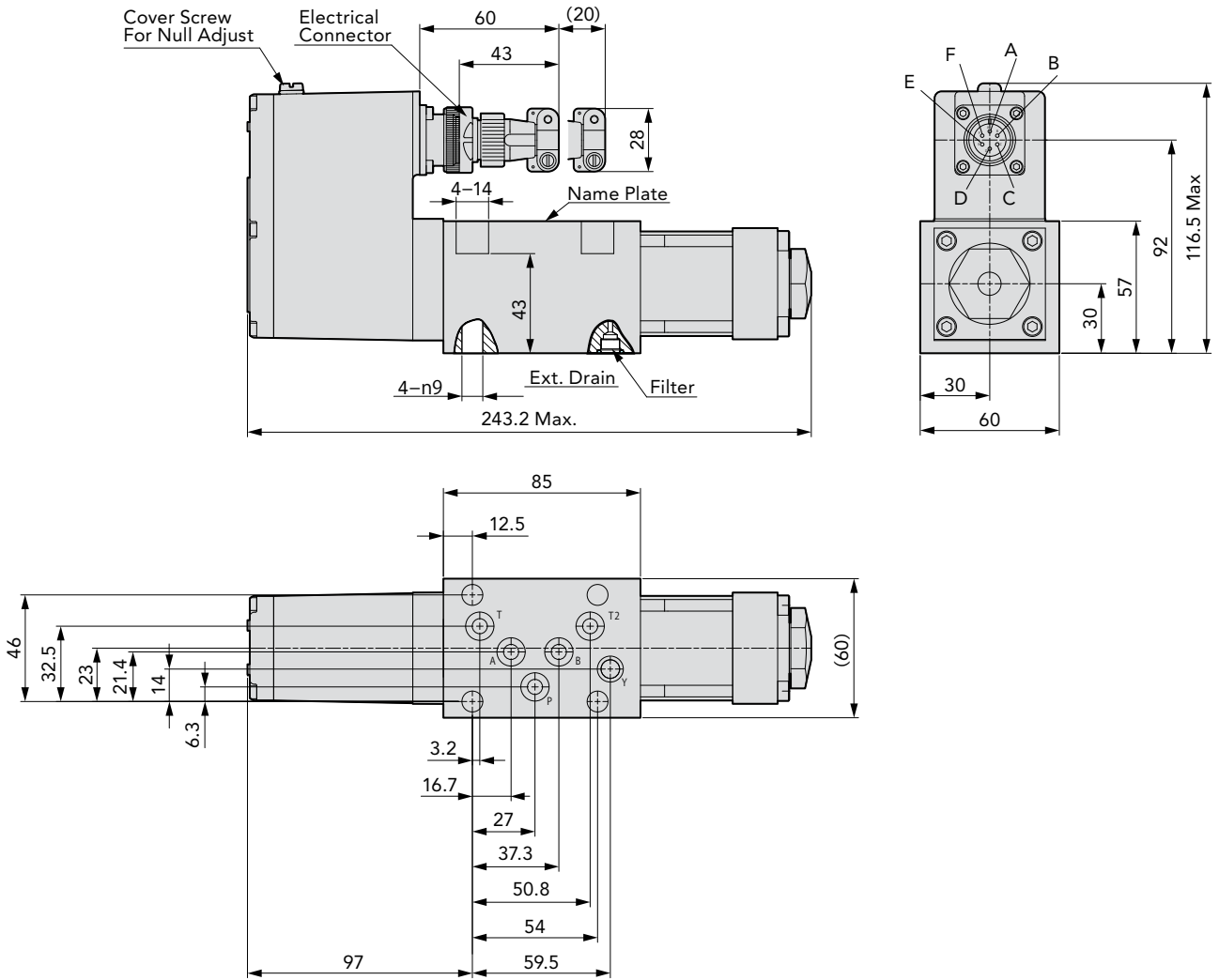

Mounting Surface

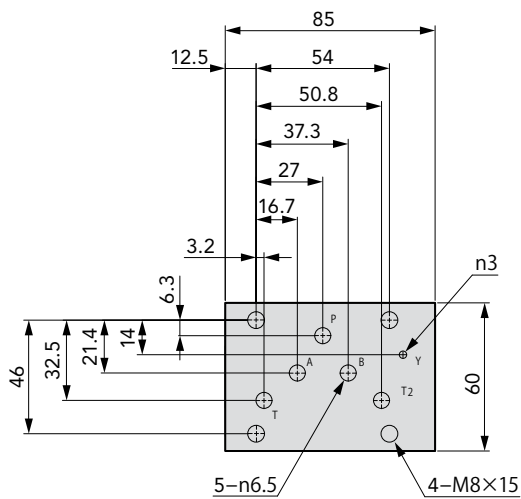

Rated Flow 20 ~ 40 L/min

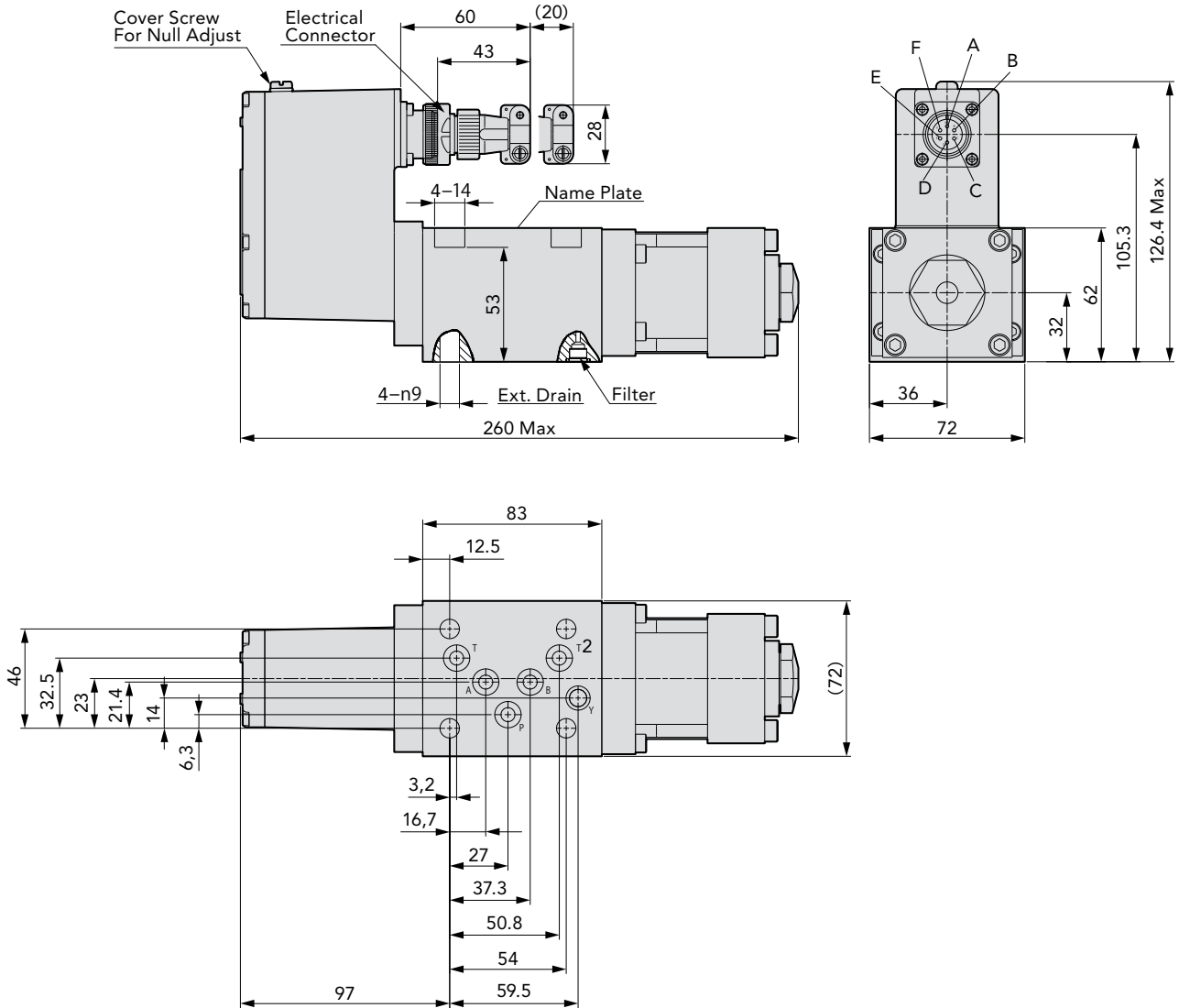

Mounting Surface

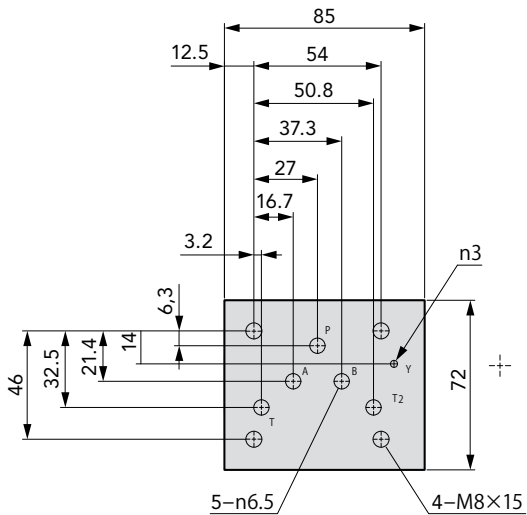

FOR MORE SPECIFIC INFORMATION

For more specific information regarding Moog products, solutions or services, please Email us, or visit our website. You may also directly contact your local Moog office.

Argentina
+54 11 4326 5916
info.argentina@moog.com

India
+91 80 4057 6666
info.india@moog.com

Singapore
+65 677 36238
info.singapore@moog.com

Australia
+61 3 9561 6044
info.australia@moog.com

Ireland
+353 21 451 9000
info.ireland@moog.com

South Africa
+27 12 653 6768
info.southafrica@moog.com

Brazil
+55 11 3572 0400
info.brazil@moog.com

Italy
+39 0332 421 111
info.italy@moog.com

Spain
+34 902 133 240
info.spain@moog.com

Canada
+1 716 652 2000
info.canada@moog.com

Japan
+81 46 355 3767
info.japan@moog.com

Sweden
+46 31 680 060
info.sweden@moog.com

China
+86 21 2893 1600
info.china@moog.com

Korea
+82 31 764 6711
info.korea@moog.com

Switzerland
+41 71 394 5010
info.switzerland@moog.com

Finland
+358 10 422 1840
info.finland@moog.com

The Netherlands
+31 252 462 000
info.thenetherlands@moog.com

Turkey
+90 216 663 6020
info.turkey@moog.com

France
+33 1 4560 7000
info.france@moog.com

Norway
+47 6494 1948
info.norway@moog.com

United Kingdom
+44 168 429 6600
info.uk@moog.com

Germany
+49 7031 622 0
info.germany@moog.com

USA
+1 716 652 2000
info.usa@moog.com

Hong Kong
+852 2 635 3200
info.hongkong@moog.com

www.moog.co.jp

Moog is a registered trademark of Moog Inc. All trademarks as included herein are the property of Moog Inc. and its subsidiaries.
©2013 Moog Inc. All rights reserved.

J634 Series-en_rev.A
YCO / YCO / PDF, July 2023