

DigiPack III

Parison Wall Thickness Controller

J141-215A

INSTALLATION, MAINTENANCE AND USER'S MANUAL

* This document does not contain technical data or technology as defined in the ITAR Part 120.10, EAR Part 772 or

MOOG INTELLECTUAL AND PROPRIETARY INFORMATION LEGEND

This technical Document contains information that is proprietary to, and is the express property of Moog Inc., or Moog Inc. subsidiaries except as expressly granted by contract or by operation of law and is restricted to use by only Moog employees and other persons authorized in writing by Moog or as expressly granted by contract or by operation of law. No portion of this Data/Drawing/Document shall be reproduced or disclosed or copied or furnished in whole or in part to others or used by others for any purpose whatsoever except as specifically authorized in writing by Moog Inc.

RECORD OF CHANGES

Rev.	Page	Description	Prepared	Checked	Approved
Orig.		New Model Release(EOJ23275)	T. Kouda 17, May'22	T.Shimizu 20, May '22	A.Miyajima 24,May'22
A	1	Delete the following text: In addition, other than the above, you can refer to the list of USB memories being used without problems by customers at the following URL: https://www.moog.co.jp/products/controllers-software/blow-molding-controllers/digi-pack3.html	T. Kouda (23, April '26)	T.Shimizu (24, April '26)	M.Nishihata (24, April '26)
	6	Change the following link: Old: https://www.moog.co.jp/products/controllers-software/blow-molding-controllers/digi-pack3.html NEW: https://www.moog.co.jp/products/controllers-drives-software/industrial-controllers-software/machine-controllers/digi-pack3.html			
	All	Update the copyright to the new format. (EOJ27068)			

NOTES TO USERS

- (1) Description in this manual is subject to change without any obligation on the part of the Manufacturer.
- (2) Notice would be appreciated if you find any question, omission or error in this manual.
- (3) Disassembly, maintenance or repair, other than in accordance with the instruction herein or other specific written instruction from MOOG will invalidate MOOG's obligations under its warranty. Refer to MOOG warranty for complete provisions thereof.

SAFETY INSTRUCTION

Description in this manual is essential to the safety of life and property, therefore, before operating this equipment, you should first thoroughly read this manual, and this manual should be kept in accessible for when you have any questions.



WARNING

This symbol with the word "WARNING" is used to call attention to safety instructions concerning a potential hazard to people. Failure to comply with these safety instructions can result in serious damage to health and can even prove fatal in extreme cases.



CAUTION

This symbol with the word "CAUTION" is used to call attention to instructions concerning potential damage to the equipment or to the system as a whole.



NOTE

Notes contain useful information to the operator when starting up and operating the equipment or system.

MOOG JAPAN LTD.

1-8-37 NishiShindo, Hiratsuka, Japan 254-0019

Tel: +81-463-55-7141

About EMC Standard

1. Safety standard

Notes to certified of EC directive

J141-215A DigiPackIII is a device incorporated in customer's equipment (blow molding machine) and we are conducting EMC test against EC Directive within the scope of embedded equipment, but the J141-215A DigiPackIII use by itself is not compatible with the EC Directive.

When customer completes the equipment with J141-215A and use it within Europe or shipment to the area within European region as the final product, please be sure to check certified of EC Directive by customer self.

Applicable directive and relative standard.

J141-215A is conducting the EMC test conforming to the EC directive below. It shows directives and related standards.

EC Directive: EMC Directive 2014/30/EU

Relative Standard:

EN 61000-6-2:2005 IEC61000-4-2~6	Electromagnetic compatibility (EMC) - Part 6-2: Generic standards - Immunity for industrial environments
EN61000-6-4:2007+A1:2011	Industrial, scientific and medical equipment - Radio-frequency disturbance characteristics - Limits and methods of measurement

2. Measures EMC

In order to applicable EMC directive, please takes suitable measure against EMC with a customer's blow molding machine.

And also, when include J141-215A in apparatus and it is used, please consider wire connection and grounding.

The cable used for each wire connection recommends use of a shielded cable.

A shielded cable should be connected to the terminal of J141-215A, and the length of skin wire processing should be less than 100 mm.

TABLE OF CONTENTS

1. DigiPack III Manual, Installation and Maintenance.....	1
1-1. CHANGES FROM OLD CONTROLLER	1
1-2. INTRODUCTION.....	2
1-2-1. GENERAL DESCRIPTION.....	2
1-2-2. WHO CAN INSTALL THE DigiPack III	5
1-2-3. INSTALLATION TIME	5
1-2-4. SOFTWARE UPDATE	6
1-2-5. BACKUP BATTERY	7
1-2-6. SCREEN DISPLAY PROTECTION (password).....	7
1-2-7. DATA TRANSFER FROM DigiPack II	7
1-3. DigiPack III SPECIFICATION.....	8
1-4. CHECK LIST	9
1-4-1. INSTALLATION CHECK LIST	9
1-5. MECHANICAL INSTALLATION	10
1-5-1. GENERAL	10
1-5-2. TOOLING ADJUSTMENT	11
1-5-3. MOOG DIE GAP TOOLING ACTUATORS	12
1-5-4. CYLINDER INSTALLATION	12
1-5-5. CUSTOMER SUPPLIED CYLINDER REQUIREMENTS.....	13
1-5-6. TOOLING ADJUSTMENT	14
1-5-7. ACCUMULATOR POSITION MEASUREMENT	14
1-5-8. THE IMPORTANCE OF FILTRATION	15
1-5-9. FILTER INSTALLATION	15
1-5-10. HYDRAULIC POWER SUPPLY	16
1-5-11. HYDRAULIC POWER SUPPLY START UP INSTRUCTIONS	16
1-5-12. CONTAMINATION CONTROL	17
1-6. ELECTRICAL INSTALLATION.....	18
1-6-1. GENERAL	18
1-6-2. REAR CONNECTOR.....	18
1-6-3. TB-1, TB-2 WIRING	19
1-6-4. COMMUNICATION AND SSI SENSOR WIRING.....	19
1-6-5. TB-2 I/O CIRCUITRY	25
1-6-6. TB-3: POWER SUPPLY	26
1-6-7. NOISE AND GROUND ISOLATION	26

1-7. CALIBRATION OF TOUCH SCREEN	29
1-8. DigiPackIII front panel	30
1-9. TOOLING SYSTEM SETUP	32
1-9-1. GENERAL OF SETUP	32
1-9-2. MACHINE SETTING	32
1-9-3. SET UP PROCEDURE	35
2. DigiPackIII Manual, User operation	43
2-1. INTRODUCTION.....	43
2-2. PARISON CONTROL.....	44
2-2-1. HISTORY	44
2-2-2. PARISON PROGRAMMING BENEFITS	44
2-2-3. CONTINUOUS EXTRUSION MACHINES	44
2-2-4. ACCUMULATOR MACHINES	44
2-2-5. PARISON PROGRAMMING BENEFITS	45
2-2-6. WITH ACCUMULATOR BLOW MOLDING MACHINES	46
2-2-7. WITH CONTINUOUS BLOW MOLDING MACHINES	46
2-2-8. PARISON MOLD ALIGNMENT	47
2-3. MAN MACHINE INTERFACE	48
2-3-1. OPERATOR CONTROL.....	48
2-3-2. INPUT FUNCTION.....	48
2-3-3. FUNCTIONS.....	51
2-3-4. STATE MONITORING AREA	51
2-3-5. EDIT AREA	52
2-4. SCREENS OF EDIT AREA.....	53
2-4-1. EDITING METHOD.....	53
2-4-2. F1: Profile Mode	54
2-4-3. F2: Marker Mode	59
2-4-4. F3: File Mode.....	61
2-4-5. F4: Monitor Mode.....	65
2-4-6. F5: Data Display Mode	66
2-4-7. SHIFT→F1: Set Up Mode	67
2-4-8. SHIFT→F2: Analog monitor	67
2-4-9. SHIFT→F3: File delete and Backup/Restore	68
2-4-10. SHIFT→F4: Machine Setup	69
2-4-11. SHIFT→F5: Communication Mode.....	70
2-5. COMMUNICATION PROTOCOL.....	71
2-5-1. EtherNET COMMUNICATION SPECIFICATION.....	71

2-5-2. PROFILE	71
2-5-3. WAVE	73
2-5-4. MONITOR.....	73
2-5-5. INFORMATION DATA	73
2-5-6. INTERFACE CONTROL	74
2-5-7. OTHER	76
2-5-8. ERROR CODE	76
2-5-9. ADC/DAC CHANNEL	76
2-6. PROFILE DATA LIST	77
2-7. SETTING UP	78
2-7-1. OBJECTIVE.....	78
2-7-2. DIE GAP TOOLING SETUP.....	78
2-7-3. PRELIMINARY SET UP	79
2-7-4. INITIAL TRIALS	80

Reference Drawings

CD24474 ----- Installation

CC70355----- Customer Wiring

Table of Figure

Figure 1-1 DigiPackIII appearance - - - - - Page 2

Figure 1-2 Basic Continuous Blow Molding Machine Control Diagram- - - Page 3

Figure 1-3 Basic Accumulator Machine Control Diagram- - - Page 4

Figure 1-4 Start up Display - - - - - Page 6

Figure 1-5 Die Gap Tooling Actuator Installation - - - - - Page 10

Figure 1-6 Die Gap Tooling Actuator- - - - - Page 10

Figure 1-7 Actuator – Die Gap Tooling Mechanical Adjustment - - - Page 11

Figure 1-8 Tooling Adjustment Mechanism - - - - - Page 11

Figure 1-9 Typical Cylinder Installation - - - - - Page 12

Figure 1-10 G631-XXX Servo Valve - - - - - Page 13

Figure 1-11 Typical Linear Potentiometer - - - - - Page 14

Figure 1-12 LWHxxx Potentiometer Installation- - - - - Page 14

Figure 1-13 High Pressure Filter - - - - - Page 15

Figure 1-14 Hydraulic Power Supply - - - - - Page 16

Figure 1-15 Flow Pressure Filter - - - - - Page 17

Figure 1-16 REAR CONNECTOR - - - - - Page 18

Figure 1-17 DigiPackIII Installation Drawing - - - - - Page 20

Figure 1-18 Servo Valve and Transducer Phasing- - - - - Page 21

Figure 1-19 TB-1 Connections - - - - - Page 21

Figure 1-20 TB-1 Functions - - - - - Page 22

Figure 1-21 TB-2 Connection - - - - - Page 23

Figure 1-22 TB-2 Connection - - - - - Page 23

Figure 1-23 TB-2 Functions - - - - - Page 24

Figure 1-24 Input use external Power supply - - - - - Page 25

Figure 1-25 Input use internal Power supply - - - - - Page 25

Figure 1-26 Output use external Power supply - - - - - Page 25

Figure 1-27 Output use internal Power supply- - - - - Page 25

Figure 1-28 Power supply Connections - - - - - Page 26

Figure 1-29 Accumulator Machine Timing chart - - - - - Page 27

Figure 1-30 Continuous Machine Timing chart - - - - - Page 28

Figure 1-31 Touch screen Calibration - - - - - Page 29

Figure 1-32 Touch screen calibration display - - - - - Page 29

Figure 1-33 DigiPackIII Flont panel - - - - - Page 30

Figure 1-34 Machine setup display (SHIFT→F4) - - - - - Page 33

Figure 1-35 Machine setting Functions - - - - - Page 33

Figure 1-36 Example of profile points change- - - - - Page 34

Figure 1-37 Setup screen - - - - - Page 35

Figure 1-38 Die Converge/Diverge Setup- - - - - Page 35

Figure 1-39 Die Gap Setup- - - - - Page 36

Figure 1-40 DCDT Noise Filter - - - - - Page 36

Figure 1-41 Die Gap Span Setting - - - - - Page 37

Figure 1-42 Back - - - - - Page 38

Figure 1-43 Gain select - - - - - Page 39

Figure 1-44 Gain setting - - - - - Page 39

Figure 1-45 Accumulator Setup - - - - - Page 40

Figure 1-46 EMPTY Accumulator Set Up - - - - - Page 40

Figure 1-47 FULL Accumulator Set Up - - - - - Page 41

Figure 1-48 Extrusion Fixed- - - - - Page 41

Figure 1-49 Filling Fixed - - - - - Page 41

Figure 1-50 Accumulator setting (Back) - - - - - Page 42

Figure 2-1 DigiPackIII appearance - - - - -	Page 43
Figure 2-2 Section of an Un-programmed Parison and the Resulting Container Walls	Page 45
Figure 2-3 Section of a Programmed Parison and the Resulting Container Walls -	Page 45
Figure 2-4 Poor Vertical Alignment Between the Parison and the Mold - -	Page 47
Figure 2-5 Good Vertical Alignment Between the Parison and the Mold. - -	Page 47
Figure 2-6 DigiPackIII Front panel - - - - -	Page 48
Figure 2-7 Ten key on the screen (1) - - - - -	Page 49
Figure 2-8 Ten key on the screen (2) - - - - -	Page 49
Figure 2-9 Status indicator - - - - -	Page 52
Figure 2-10 F1: Profile mode Screen - - - - -	Page 53
Figure 2-11 Profile Mode Screen - - - - -	Page 54
Figure 2-12 0%Weight Change - - - - -	Page 56
Figure 2-13 (-)23.3% Weight Change - - - - -	Page 56
Figure 2-14 0% Range H - - - - -	Page 57
Figure 2-15 (+)25.0% Range H Change - - - - -	Page 57
Figure 2-16 0% Range L - - - - -	Page 58
Figure 2-17 (-)20.0% Range L - - - - -	Page 58
Figure 2-18 Marker Mode Screen - - - - -	Page 59
Figure 2-19 Slope Timing - - - - -	Page 60
Figure 2-20 File Mode Selection Screen - - - - -	Page 61
Figure 2-21 Select SAVE - - - - -	Page 61
Figure 2-22 File Description Data-Page 1 - - - - -	Page 62
Figure 2-23 File Description Data-Page 2 - - - - -	Page 62
Figure 2-24 File Description Data-Page 3 - - - - -	Page 62
Figure 2-25 Edit File name - - - - -	Page 63
Figure 2-26 Change File Number - - - - -	Page 63
Figure 2-27 Initial Load Screen - - - - -	Page 64
Figure 2-28 File Load - - - - -	Page 64
Figure 2-29 F4: Monito screen - - - - -	Page 65
Figure 2-30 Data Display Screen A - - - - -	Page 66
Figure 2-31 Data Display Screen B - - - - -	Page 66
Figure 2-32 Data Display Screen C - - - - -	Page 66
Figure 2-33 [SHIFT]→[F1]: Setup Screen - - - - -	Page 67
Figure 2-34 [SHIFT]→[F2]: Analog Monitor Screen- - - - -	Page 67
Figure 2-35 [SHIFT]→[F3]: File delete and Backup - - - - -	Page 68
Figure 2-36 File Delete - - - - -	Page 69
Figure 2-37 [SHIFT]→[F4]: Machine Setup Screen - - - - -	Page 69
Figure 2-38 [SHIFT]→[F5]: Communication Mode Screen - - - - -	Page 70

1. DigiPackIII Manual, Installation and Maintenance

1-1. CHANGES FROM OLD CONTROLLER

The basic specifications of DigiPackIII (J141-215A) are equivalent to conventional J141-214A and J141-215.

There are the following major differences from J141-214A.

- Change LCD size and touch screen
Changed from current VGA (480 x 640) to WXGA (1200 x 800) size
In addition, with touch screen conversion, operation by the conventional push button switch and display by the LED are abolished, and it is changed to operation/display on the screen. (Excluding rotary knob and power supply confirmation LED)
- Change the storage device from SD card to USB memory stick
Considering availability, change the external storage device to USB memory. (It is not attached to controller)
The following USB memory has been tested for operation. The operation can not be guaranteed with USB memory other than these model numbers. We recommend that you select the same model number as below when purchasing.
 - Sony USB Media R Series 16 GB USM 16 GR
 - Elecom USB Memory 16GB MF-HTU3A 16GBK
- The rear terminal block was screw-tightened, and the terminal block was made detachable.
Mounting screw size is M3.5. Please use crimp terminal matching it.
Also, since the terminal block is removable, rewiring is unnecessary when replacing the controller.
- Change / add digital signal
 - Name change: DI 10 Servo OFF → Emergency. This signal is normally (under control) OFF, and if input is ON, turns OFF the servo output. For details, refer to Figure 1-23 TB-2 Functions .
 - Signal addition: DI 11 temperature up completion. This signal is normally (under control) OFF, and if input is ON, turns OFF the servo output. (Please turn ON when the resin is sufficiently warmed up and it becomes operable.) Please refer to Figure 1-23 TB-2 Functions for details.
- The following functions have been abolished.
 - RS422 serial communication function
 - SSI / encoder input connector (feedback signal)
 - Pulse output command signal
 - Some digital inputs / outputs (F1 to F4 / production completed / marker OUT 2)

There are the following major differences from J141-215.

The specifications have been met so far, but in order to further improve the quality, the following changes have been made to improve the waterproofness.

- The entire front panel is covered with a protective sheet to prevent liquid from entering between the LCD and the front panel.
- By blocking the ventilation holes on the upper surface of the rear cover, liquid intrusion is prevented.

* There are no changes to the operation method, functions, and wiring from J141-215.

For other details, please check this manual in detail.

1-2. INTRODUCTION

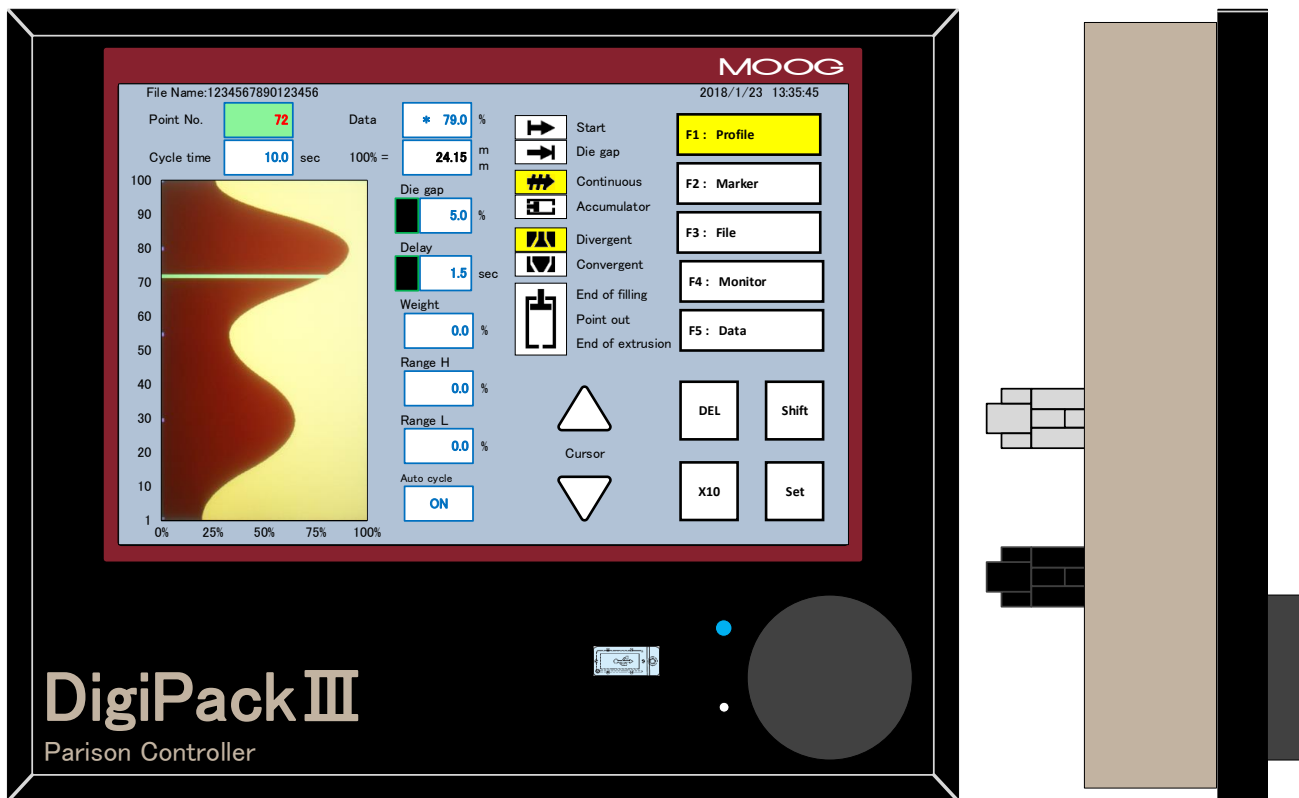

Figure 1-1 DigiPack III appearance

1-2-1. GENERAL DESCRIPTION

The J141-215A **DigiPack III** is a user friendly, high performance 200 Point Digital Blow Molding Parison Wall Thickness controller producing lighter, stronger containers at increased production rates.

A properly installed and intelligently used system will deliver higher operating efficiency from your blow molding machine as a result of faster molding cycles, shorter change over times and reduced scrap.

The DigiPack III adjusts the parison wall thickness by controlling the core position with the core actuator. The core position can be finely set up to 200 points maximum.

For an accumulator type blow molding machine, set the target core position with reference to the accumulator position. For a continuous blow molding machine, set the target core position based on time.

The core position control system with the above setting consists of four main components: DigiPack III controller, servo valve, actuator for core and feedback detector for accumulator. The function of each component is as follows.

- ✓ Operator using DigiPack III to set the core position (core die gap opening / closing amount) required to obtain a product with the desired wall thickness (usually constant wall thickness). In addition, it outputs a flow (spool position) command to the servo valve so that the core follows the set core position.
- ✓ DigiPack III also functions as a digital interface with the PLC controller of the blow molding machine and provides information such as the end of the program and the point status of sequential programs.
- ✓ The servo valve adjusts the flow rate to the core actuator according to the flow (spool position) command from DigiPack III.

- ✓ The actuator for the core, the core is fixed to the rod, and the rod (core) moves according to the flow rate adjusted by the servo valve. Moving the core changes the gap through which the parison passes and controls the wall thickness of the parison.
- ✓ Accumulator feedback detector is used for accumulator type blow molding machine. The DigiPack III changes the target core position while monitoring the signal from this detector.

1.2.1.1. Continuous blow molding machines

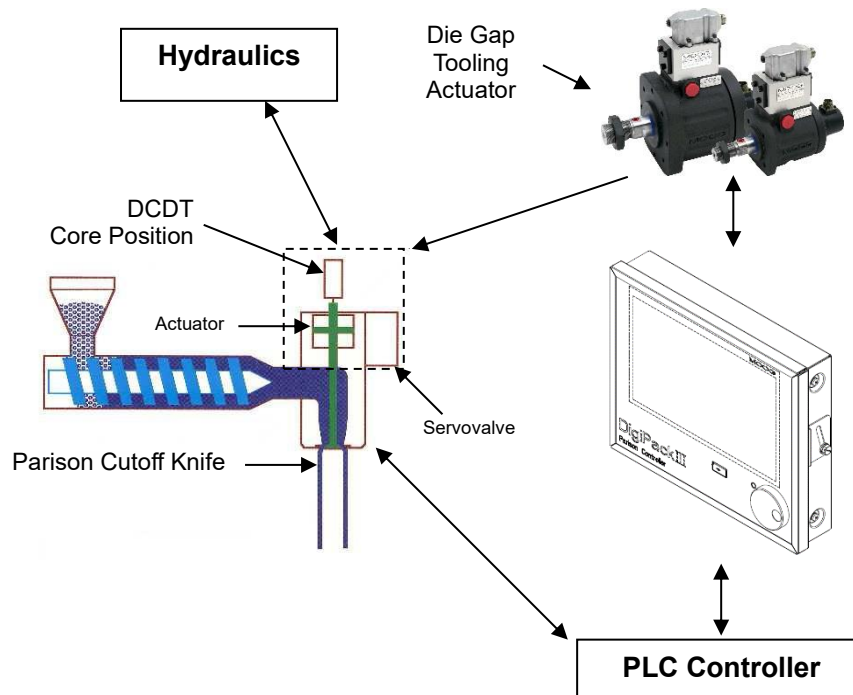

Figure 1-2 Basic Continuous Blow Molding Machine Control Diagram

When used with continuous blow molding machines, the **DigiPack III** controls the parison wall thickness relative to the machine cycle time. The machine cycle starts when the start signal is input (when the parison cutting knife disconnects the parison). The cycle time can be determined by the following.

- a) Fixed cycle time set by the operator (when [Auto cycle] is OFF)
- b) Automatic cycle time set by repeatedly measuring the time between start signals (when [AUTO CYCLE] is ON)

When using the fixed cycle time of a), it is necessary for the machine operation time to be negligible for reasons such as multiple die interlocking, or it is a premise that it is a machine that performs machine functions such as closing and moving molds within the cycle time.

The shape of the parison wall profile is set digitally by the operator. The size of the die gap, measured by a die gap position transducer, is compared with the operators commanded position as set on the **DigiPack III** display.

The error between the operators set position and the actual position causes the servo valve to flow oil to the actuator to reduce the position error to a very small value. This feedback process ensures that the actual die gap follows the commanded die gap very accurately.

With a continuous blow molding machine, DigiPack III operates / processes as follows.

- ① The operator sets the core position (core die gap opening / closing amount) necessary to obtain the desired wall thickness (usually constant wall thickness) product on the DigiPack III controller panel.
- ② When the start signal switches from OFF to ON, DigiPack III controls the servo valve so that the core follows the set position according to the cycle time.

- ③ The servo valve adjusts the flow rate to the core actuator according to the (flow rate) command from DigiPackIII.
- ④ By controlling the actuator for the core, control the thickness of the parison at the core die gap portion.
- ⑤ During ② to ④, DigiPackIII functions as a digital interface with the PLC of the blow molding machine and provides information such as the end of the program and the point status of the program sequentially.

1.2.1.2. Accumulator type molding machines

When used with accumulator machines, the **DigiPackIII** controls the parison wall thickness relative to the accumulator position as the plastic is being extruded.

As the total quantity or volume of plastic extruded is proportional to the accumulator position, then it follows that the resulting parison wall thickness at any given point on the length of the container must be related to the accumulator position. Given that the physical properties of the plastic and its temperature are constant from container to container, then each container's weight and strength will be consistent.

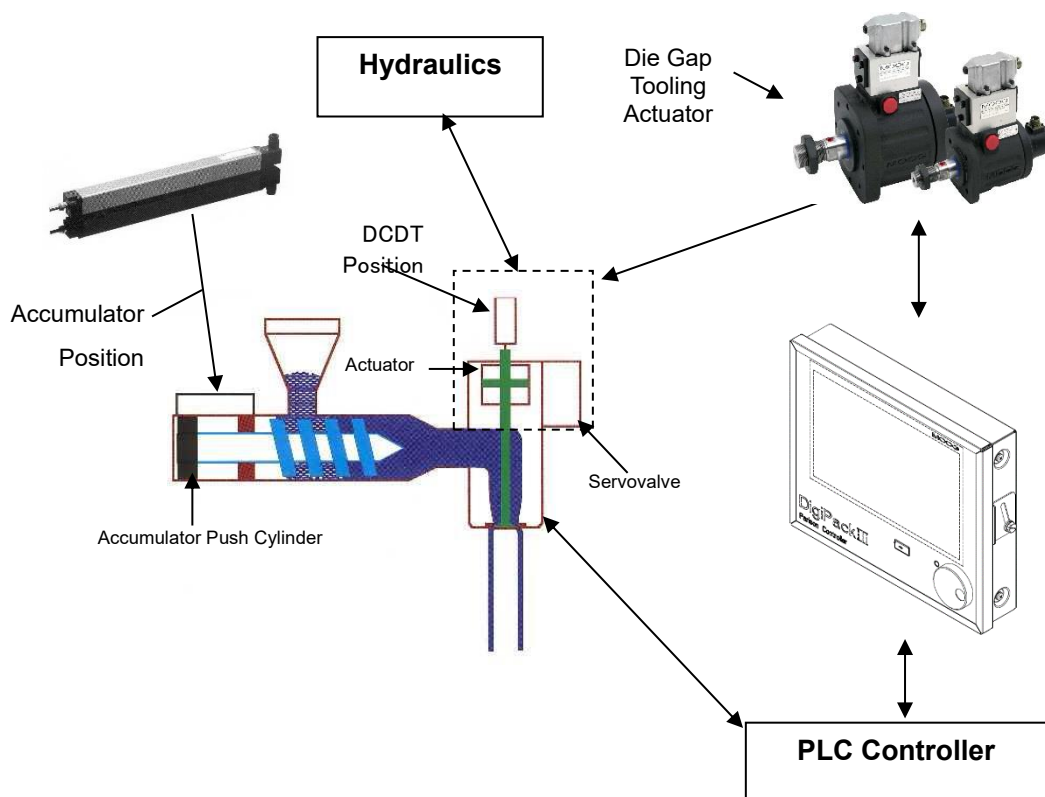

Figure 1-3 Basic Accumulator Machine Control Diagram

A potentiometer measures the accumulator position and controls the vertical axis of the program display. The operator can also set the accumulator operating stroke, shot size, and accumulator injection completion position (cushion). In addition, DigiPackIII also provides interface signals to the machine's PLC for these functions. After that, the operation of the accumulator is controlled by the PLC.

With an accumulator type blow molding machine, DigiPackIII operates / processes as follows.

- ① The operator sets the core position (core die gap opening / closing amount) necessary to obtain the desired wall thickness (usually constant wall thickness) product on the DigiPackIII controller panel.
- ② When the start signal switches from OFF to ON, the DigiPackIII controls the servo valve so that the core follows the set position according to the position of the accumulator.

- ③ The servo valve adjusts the flow rate to the core actuator according to the (flow rate) command from DigiPackIII.
- ④ By controlling the actuator for the core, control the thickness of the parison at the core die gap portion.
- ⑤ During ② to ④, DigiPackIII functions as a digital interface with the PLC of the blow molding machine and provides information such as the end of the program and the point status of the program sequentially.

Successful performance of the **DigiPackIII** depends a great deal upon how well it is installed on the machine. By following the instructions contained idatan this manual it will be possible to easily install this system and obtain many years of trouble free operation.

1-2-2. WHO CAN INSTALL THE DigiPackIII

The installation of the **DigiPackIII** control system requires the installer to be familiar with electrical wiring, hydraulic plumbing and basic metal working. The calibration and start up of the finished system requires some understanding of the blow molding process and use of test instruments such as a digital voltmeter. The plumbing, wiring and bracketry should not be difficult. Most molding shop maintenance men who are familiar with blow molding machines will have little difficulty with the help of this manual.

The system can be satisfactorily calibrated to the machine and started up without assistance or special equipment by following the instructions in this manual.

1-2-3. INSTALLATION TIME

The time to install a **DigiPackIII** varies with the type and size of machine, mechanical constraints such as the location of water lines and auxiliary equipment and the ability of the mechanic doing the installation.

Our experience has shown that typical maintenance men will require about 20 to 30 man hours. Smaller machines will require less time.

Of this time, the actual machine shut down time can be held to 6 hours or less.

1-2-4. SOFTWARE UPDATE

The software of this controller may be updated if a bug is found or the function is improved. Please check the software update status (latest version) from the MOOG website below. Also you can download the update file "DIGIPK3.FMW" from the website. How to update Please refer to the following description.

Update Process

1. Prepare the USB memory and turn off the power of DigiPackIII.
2. Save the "DIGIPK3.FWM" file to the USB memory using the computer.
3. Insert the USB memory into the DigiPackIII and turn ON the DigiPackIII.
4. Turn the rotary knob **clockwise** while turning on the power.
5. When "Updating firmware ..." appears on the display, the update process is in progress.
 - ※ It takes about 30 seconds to update. If "Failed" is displayed on the screen, or if nothing happens and screen changed to the startup screen, the upgrade fails. Please try again from process 1. If "Failed" is inevitably displayed and the upgrade is not successful, there is a possibility that the file is broken. Please download "DIGIPK3.FWM" again and try update again.
6. Then check the software version in the startup display (Figure 1-4).
7. Turn off the power and remove the USB memory.

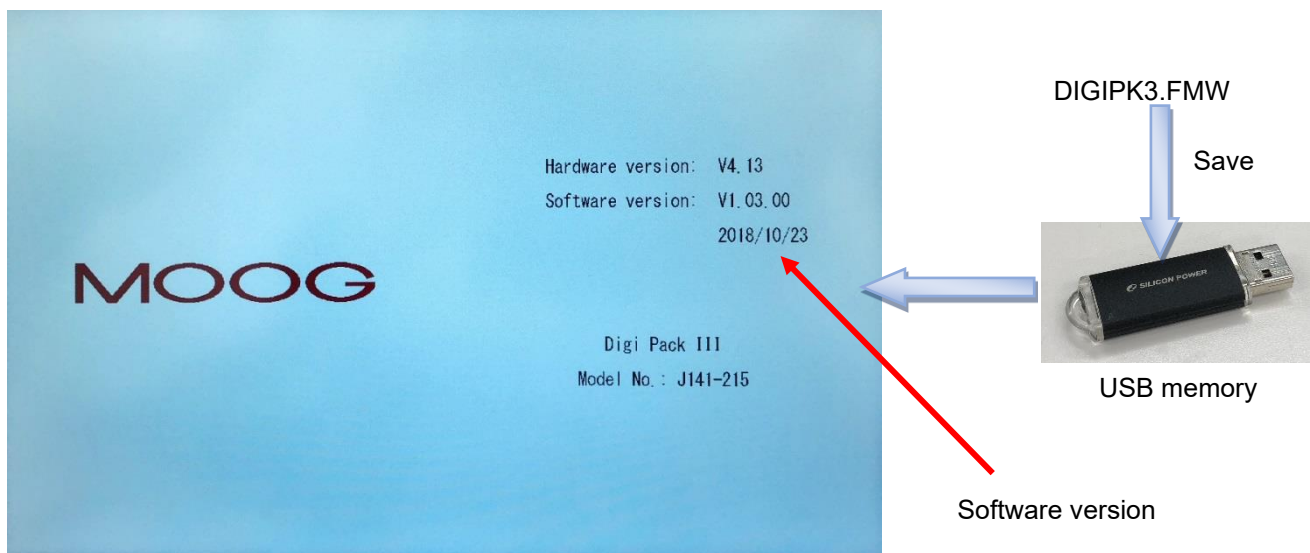

Figure 1-4 Start up Display



USB memory is not included with DigiPackIII. Refer to section 1-1. for recommended USB. "DIGIPK3.FWM" can download the latest version from the MOOG website

<https://www.moog.co.jp/products/controllers-drives-software/industrial-controllers-software/machine-controllers/digipack3.html>



1-2-5. BACKUP BATTERY

Since backup of an internal clock is using the ultra capacitor, there is no necessity for exchange. Backup time is about three weeks.

A time display may be [----.-- --:--] when not turning on electricity the time of the power activation after purchase, and for a long period of time.

In such a case, please set up the right time on F2 screen. (Reference 2-4-3.)

1-2-6. SCREEN DISPLAY PROTECTION (password)

The DigiPackIII has two types of screen configurations that the normal operation screen (F1 to F5) and the setting screen (SHIFT → F1 to F5) for making various settings. Each screen can be distinguished by the color of the background. The background color of the normal operation screen is light blue "  ". The background color of the setting screen is yellow "  ". In this controller, the transition to the setting screen is limited by the password. When entering the setting screen, entering a password enables you to migrate.

* Once you enter the password, it is not necessary to enter the password until you restart the controller. Also, if password function is unnecessary, it is possible to invalidate password from SHIFT → F4 screen. See 1.9.2.1

Password: 6009 (Password is fixed and can not be changed)

Password input

After activating the controller, the password entry screen will be displayed when entering to the setup screen by first pressing "SHIFT" and then pressed Fx key. Once you enter 4-digit password, you will be able to switch to the setup screen without entering again the password. This will be retained until you restart DigiPackIII.

In addition, this password can be enabled / disabled on the machine setting screen (SHIFT→ F4) . Refer to Section 1.9.2.1 Machine Settings for details.



This level change **does not indicate any notice** on display. Please check the level is correctly changes or not by press SHIFT→F1, if the level "Low" should not goes to setup display

1-2-7. DATA TRANSFER FROM DigiPack II

The saving data of DigiPack II can be transferred to DigiPackIII due to following process.

With the DigiPack II save the parameters file to SD Card and copy it to USB by using PC. Then, load parameter file from USB to DigiPackIII. (Refer to 2-4-4. for save/load description)

NOTE: New parameter like PURGE/TOOLING is not include.

1-3. DigiPackIII SPECIFICATION

Model Number:	J141-215A DigiPackIII.
Function:	Max 200 points Single head blow molding Parison programmer
Application:	Accumulator Based or Continuous Extrusion Blow Molding Machines can be selected.
Profile Points:	10 to 200, Custom points. And Straight or Spline interpolation can be selected.
Tooling Type:	Divergent or convergent die gap tooling types can be selected.
Tooling Position Control:	Digital closed loop servo system with a 1m sec update time.
Tooling Position Monitor:	From Tooling Position Actuator's DCDT ± 10 VDC.
Accumulator Position Monitor:	From Accumulator Potentiometer 0 to 10 VDC FS.
Programming Inputs:	By Rotaly knob and touch panel switches.
Display:	Color Display (LCD). 10.1 inch(WXGA) touch screen. English/Japanese/Chinese language selected by Parameter at Setup screen.
Memory:	100 program profile patterns can be stored in a Flash RAM. And can be stored in USB memory. ※ Supports standard USB memory, up to 32G. (Refer to 1-1.) ※ Data format: FAT32
Point Marker:	A marker output signal can be set maximum 10 program point.
Other Functions:	Shot Size, Delay, Cushion (for accumulator machines only), die gap, data saving, profile curve adjustment (Weight and Range H/L), adjustment of the tooling actuator stroke and the accumulator position transducer, backup for the system timer(by capacitor).
Output to Servovalve:	MFB type: $\pm 10, 20, 50, 100$ mA or EFB type: ± 10 VDC
Servovalve Monitor:	$\pm 100\%$ Spool Stroke equals 4-20mA
I/O for Accumulator:	0 to 10 VDC transducer output and 10 V DC transducer excitation.
I/O for Tooling Position:	± 10 VDC DCDT output and ± 10 V DC DCDT excitation.
Common External Input:	Photo Coupler Isolated Customer Supplied 15 to 24 Vdc @ 10 mA /Channel
24 VDC External Outputs:	Photo MOS Relay Customer Supplied 15 to 24 Vdc @ 100mA /Channel Max. Accumulator type: End of Extrusion/Filling Relay Contacts: 250Vac @ 1 A/channel MAX.
Communication:	Data transfer with host computer by RS422 and Ethernet
Power Requirements:	24 VDC $\pm 10\%$, 0.5A min (MAX 3.0A depend on Servovalve Power required) No ripple requirement : Max $\pm 10\%$
Temperature/Humidity:	0 to 45°C within 85% relative humidity
IP rating	Front side = IP20, Rear side = IP30
Dimensions:	289.3 (W) x 241.3 (H) x 56.2 (D) mm (not include terminal)
Weight:	3.6 kg

1-4. CHECK LIST

*The instructions in this section are general installation procedures.

1-4-1. INSTALLATION CHECK LIST

Order parts for installation

Identify component mounting locations and procure the necessary mounting brackets

Install the DigiPackIII unit in the blow molding machine or optional enclosure

Mount tooling servoactuator to machine

 or Mount servovalve manifold and

 or Mount DCDT to tooling actuator

Mount servo actuator pressure filter

Install hydraulic power supply

Install main system filter

Make hydraulic pressure and return connections and flush the hydraulic system,

Mount accumulator position transducer, if required

Install conduit and pull cables for the tooling servoactuator, transducers, filter differential pressure switch and interface between the DigiPackIII control panel and the machine PLC

Check the wiring

Calibrate transducers

Set up the control loop

Connect the actuator to the die gap tooling and adjust the die gap end points.

1-5. MECHANICAL INSTALLATION

*The instructions in this section are general installation procedures.

1-5-1. GENERAL

Mounting provisions for the tooling servoactuator should include a stable mounting platform for the tooling actuator, a filter location which allows the filter element to be readily replaced and mechanical provisions allowing simple adjustment of the mechanical relationship between the actuator and the die gap. Figure 1-5 shows such as a well planned installation.

A tooling servoactuator provides a long lived solution to the problems caused by high temperatures and force levels. Low friction seals and strong bearings insure long term and good tooling die gap positioning performance. A built in position transducer provides mechanical isolation from shocks and climbing feet. A directly manifold servovalve is tightly coupled to the actuator. Figure 1-6 illustrates a packaged tooling actuator with provisions for pre-blow air.

Figure 1-5 shows a typical tooling actuator installation. A servovalve (upper right) is directly mounted on a manifold, which in turn is attached to a tooling actuator. Directly below is a DCDT position transducer measuring the actuator rod and die gap tooling motion. In addition, a high pressure filter mounted directly on the manifold provides clean oil to the servovalve. Tooling adjustment provisions are also shown.

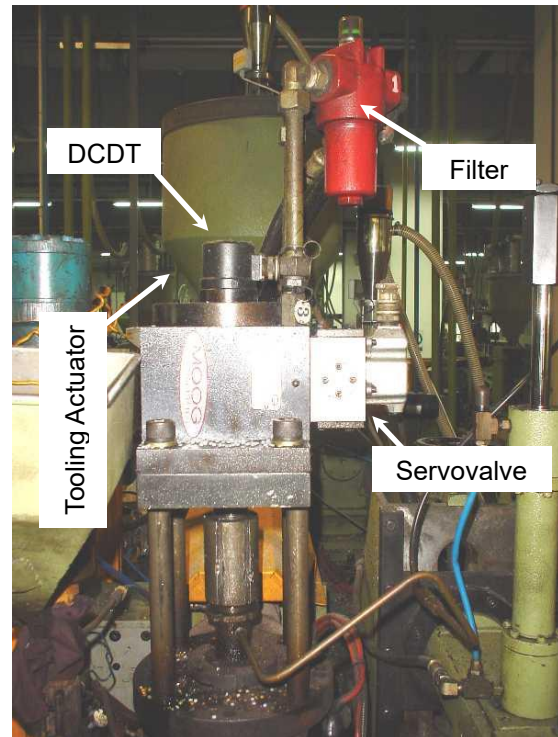
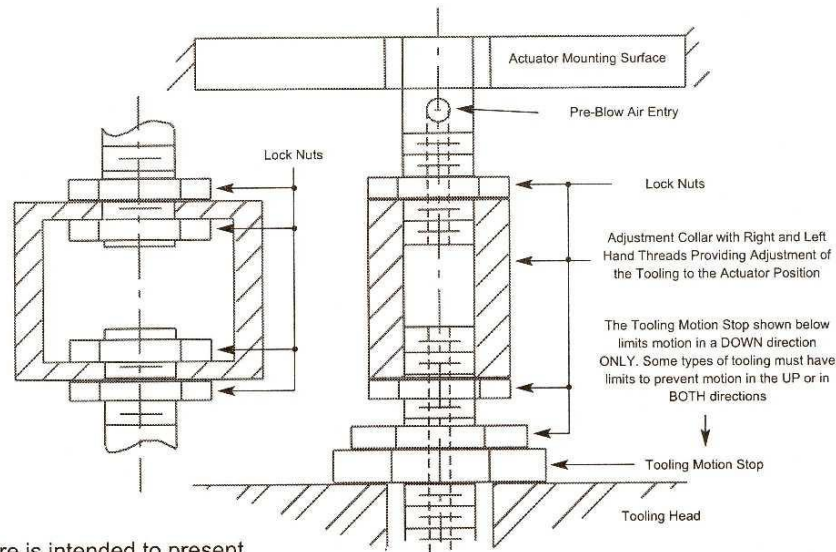

Figure 1-5 Die Gap Tooling Actuator Installation



Figure 1-6 Die Gap Tooling Actuator



NOTE:
This Figure is intended to present some design ideas **ONLY!**

Figure 1-7 Actuator – Die Gap Tooling Mechanical Adjustment

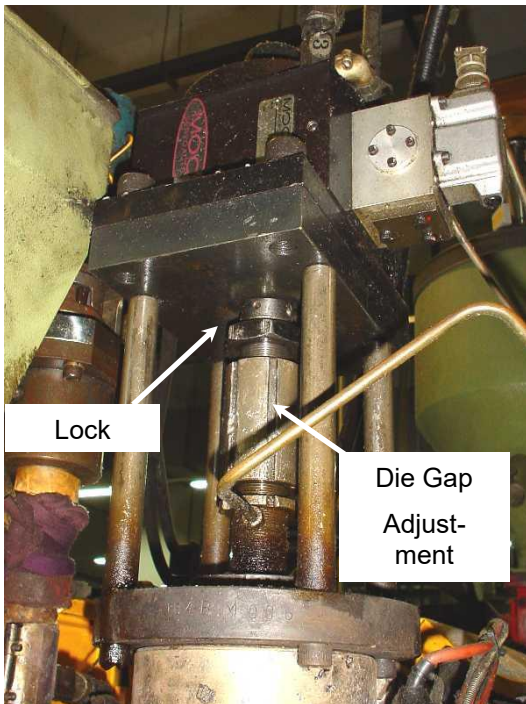



Figure 1-8 Tooling Adjustment Mechanism

1-5-2. TOOLING ADJUSTMENT

When a mold change is made, it is often necessary to change the die gap tooling assembly. Therefore the actuator installation must provide for simple adjustment of the die gap tooling position relative to the actuator position. Figure 1-7 shows two possible methods of adjusting the positional relationship between the tooling actuator and the die gap tooling's closed position. Tooling motion stops may be required to limit the forces on the die gap tooling when the die and mandrel touch. Figure 1-8 is a typical installation.



Some actuators with an anti-rotation feature require the nut torque loads on the anti-rotation device to be limited by absorbing the tightening torque with a wrench on the actuator rod flats

Tooling stops are required to insure a die gap that cannot close on a continuous molding machine. An inadvertent closure of the die gap could cause very high pressures in the extruder barrel and extrusion head and result in their damage and/or failure.

The above comments must be considered for the proper installation of either a Moog supplied die gap tooling actuator or a customer supplied actuator.



The extruder barrel and/or screw can be severely damaged if the die gap closes when the extruder is running. A mechanical motion stop must be installed which will not allow the die gap to close.

1-5-3. MOOG DIE GAP TOOLING ACTUATORS

The Die Gap Tooling Actuator is designed specifically to control the die gap motion in blow molding extrusion heads. Their design specification includes: Low friction, Long life piston and rod seals. Graphite flake cast iron rod bearings to absorb potential side loads and high temperatures. Provision for blow air through the piston rod, and pre adjusted position feedback transducer.

The mounting provisions for a die gap tooling actuator must include: a strong mounting structure, provisions for axial and parallel alignment of the tooling actuation rod (mandrel) with the die gap actuators rod, provisions to allow the actuator stroke center and the tooling's effective stroke center to coincide, tooling motion stops to protect the tooling and/or extruder. Figure 1-6 illustrates a packaged tooling actuator.

Core control Actuator (example: J085-139)			
Servo Valve(G631-3004B)	DCDT Sensor		
The actuator rod extends when the currents of the servo valve pins A, C are positive with respect to the currents of the pins B, D	Pin A	+10V	Pin C becomes positive with respect to pin D when retracting the actuator
	Pin B	-10V	
	Pin C	+OUT	Connector compatible with MS3106-14S-5S
	Pin D	-OUT	
	Pin E	N/A	

1-5-4. CYLINDER INSTALLATION

Figure 1-9 shows an installation example of Moog's die gap core control actuator.

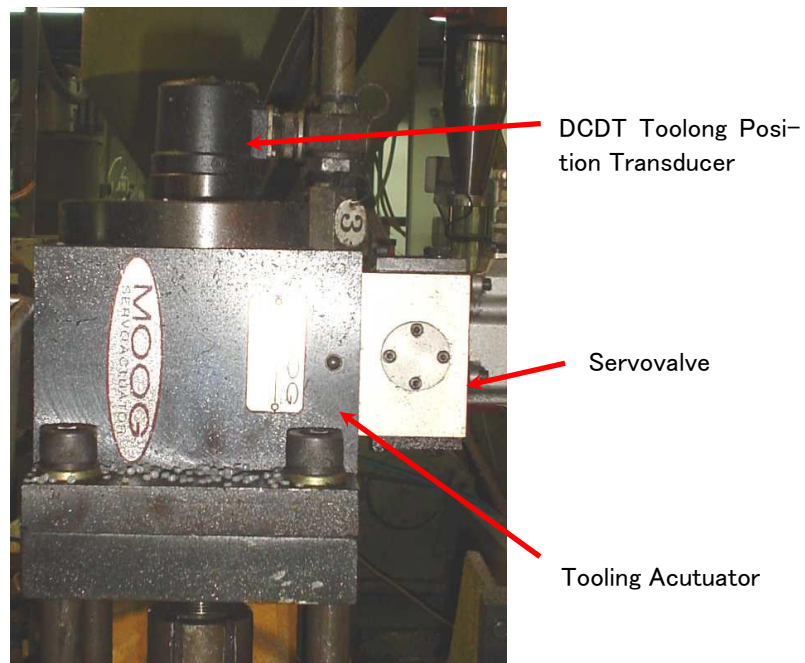

Figure 1-9 Typical Cylinder Installation

1-5-5. CUSTOMER SUPPLIED CYLINDER REQUIREMENTS

The customer supplied cylinder is required to control the die gap motion in blow molding extrusion heads. As such their purchase specification must include: Low friction, long life piston and rod seals; Robust rod bearings capable of absorbing large potential side loads and high temperatures. A quality cylinder must be purchased to meet these requirements.

The mounting provisions for the tooling actuator shall include: a strong mounting structure, provisions for axial and parallel alignment of the tooling actuation rod (mandrel) with the die gap actuators rod, provisions to allow the actuator stroke center and the tooling's effective stroke center to coincide, tooling motion stops to protect the tooling and/or extruder.



Some actuators with an anti-rotation feature require the nut torque loads on the anti-rotation device to be limited by absorbing the tightening torque with a wrench on the actuator rod flats.

1.5.5.1. MANIFOLD

The manifold must be mounted using as close as possible to the cylinder. Ideal methods are to mount the manifold directly on the cylinder, sealing the ports with “O” rings or to use tubing between the cylinder and manifold.

The pressure and return connections should be straight thread fittings using an “O” ring as a seal. Tapered thread fittings are not encouraged as they tend to leak and when they are torqued up to stop the leak, the servovalve mounting surface is distorted, causing leakage at the servovalve-manifold seal. Straight thread fittings using “O” rings do not leak or cause mounting surface distortion.

Should tapered thread fittings be used, ONLY Teflon tape can be used on the tapered threads as a sealant. The Teflon tape must not cover the last two threads at the smaller diameter portion of the thread. Any other material will cause eventual contamination problems.

Figure 1-7 shows two possible methods of adjusting the positional relationship between the tooling actuator and the tooling die gap closed position. Tooling motion stops may be required to limit the forces on the die gap tooling when the die and mandrel touch. “Figure 1-9” is a typical installation.

Tooling motion stops may also be required to insure a die gap opening on a continuous molding machine. An inadvertent closure of the die gap could cause very high pressures in the extruder barrel and extrusion head and result in their damage and/or failure. The above comments must be considered for the proper installation of either a Moog supplied die gap tooling actuator or a customer supplied actuator.

1.5.5.2. SERVOVALE MOUNTING

The servovalve is mounted to a manifold with four mounting screws and using four “O” rings to seal the Pressure, Return (Tank), and the two Cylinder hydraulic connections.

The “O” ring seal between the servovalve and manifold depends upon the servovalve mounting manifold surface flatness to insure that there are no oil leaks. This surface must be flat within 0.025mm and have a $\sqrt{32}$ RMS finish.

Two servovalves mounting patterns are available: a Cetop 5, NG 10 or a Ø22,2mm, Moog 76 port circle.



Figure 1-10 G631-XXX Servo-

1-5-6. TOOLING ADJUSTMENT

When a mold change is made, it is often necessary to change the die gap tooling assembly. Therefore the actuator installation must provide for simple adjustment of the die gap tooling position relative to the actuator position.



The extruder barrel and/or screw can be severely damaged if the tooling die gap closes when the extruder is running. A mechanical motion stop must be installed which will not allow the die gap to close.

1-5-7. ACCUMULATOR POSITION MEASUREMENT

If the DigiPackIII is being installed on a continuous extrusion machine please go to the next section.

Accumulator type blow molding machines require a position transducer to indicate the accumulator position. The parison wall thickness pattern can then be programmed with direct reference to the accumulator stroke of Shot Size.

1.5.7.1. INSTALLATION REQUIREMENTS

The position transducer is required to operate in a high temperature and vibration environment. In addition the transducer must accommodate some mechanical miss-alignment without reduction of life and linearity.

The part of position sensor allows adjustment for interlocking the movable part of the potentiometer with the moving of the accumulator. and also has the following functions:

- 1) An accumulator driven bearing guided structure for the potentiometer drive arm
- 2) Mounting provisions for the potentiometer on the same bearing guided structure, provisions for adjustment to insure parallel motion of the potentiometer guide arm and potentiometer drive rod
- 3) And a rod end bearing between the potentiometer drive rod and the potentiometer guide arm

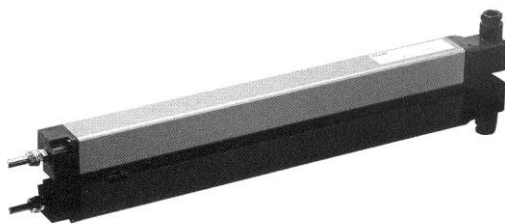

Figure 1-11 Typical Linear Potentiometer

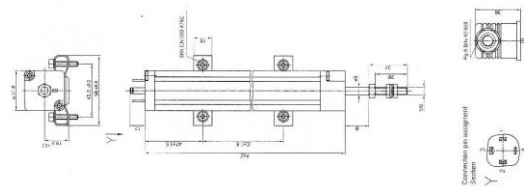

Figure 1-12 LWHxxx Potentiometer Installation

Installation Information

LWH		300	500	750	900
Electrical Data					
Rated Stroke	mm	300	500	750	900
Nominal Resistance	Kohm	5	5	10	10
Independent Linearity	%	0.07	0.05	0.05	0.05
Mechanical Data					
	mm				
Mechanical Stroke	B	312	515	769	922
Body Length	A	375	579	833	985
Mounting Feet Spacing	X	280.5	484.5	738.5	890.5

1-5-8. THE IMPORTANCE OF FILTRATION

Adequate contamination control in any hydraulic system is the key to a highly reliable system. Proper filter placement and selection insures long term trouble free operation of every hydraulic system component. There are three essentials:

- 1) a high pressure filter mounted directly at the tooling actuator
- 2) a re-circulating circuit providing continuous filtration and heat removal
- 3) proper control of the tank breathing and filling operations to prevent the ingress of contaminant

High pressure filter ($\beta_{15} \gg 75$, 15μ absolute) mounted directly with tubing at the tooling actuator provides protection against particles created by component failures.

The main contamination protection is provided by oil taken from one corner of the tank, flowing through the low pressure re-circulating filter back to the opposite corner of the tank. The re-circulation filter is a low pressure filter ($\beta_3 \gg 75$, 3μ absolute) with an inexpensive replacement filter element. The re-circulation also incorporates a heat exchanger to maintain low oil temperature and insure adequate oil life.

Protection against ingress of contaminant during oil make up and normal breathing is provided with breather rated at 10μ .



Currently, MOOG does not sell filters. Please purchase directly from the filter manufacturer.

1-5-9. FILTER INSTALLATION

High pressure filter or equivalent, $\beta_{15} > 75$ rated, high pressure filter must be mounted as close as possible (50mm to 300mm) to the actuator or servovalve manifold. The location of the filter must allow an easy access to make a replacement of filter element easy and safety.

Filter Installation Information

The hydraulic connection between the filter and actuator must be tubing. Under no circumstances can hydraulic hose be used as the hose is a contaminant generator and this contaminant will go directly into the servovalve, eventually causing contamination problems.

The hydraulic connections used will be a straight thread "O" ring sealed boss into the servoactuator and high pressure filter with either flared or compression fittings used to connect the tubing to the straight thread fittings.

The use of tapered thread fittings with pipe dope will cause both contamination and leakage problems. Teflon tape may be used, but only if applied in such a manner as to keep the edge of the Teflon tape at least two threads away from the end of the fitting.



Figure 1-13 High Pressure Filter

1-5-10. HYDRAULIC POWER SUPPLY

The Hydraulic Power Supply provides clean oil to the die gap tooling actuator at a constant supply pressure. An accumulator provides the peak flows that may be required. A water heat exchanger ensures reasonable oil temperatures.

The Hydraulic Power Supply is normally used on first installations when the cleanliness condition of the blow molding machine's hydraulic power supply is unknown or suspect.

A separate hydraulic power supply provides a reliable source of clean oil for trouble free long term operation. A bypass filter allows the oil to be continually cleaned and cooled.

The hydraulic power supply pressure output should be connected directly to the input port of the high pressure filter at the die gap tooling actuator or the servovalve manifold. The actuator or manifold return line goes to the hydraulic power supply return port.



Figure 1-14 Hydraulic Power Supply

1-5-11. HYDRAULIC POWER SUPPLY START UP INSTRUCTIONS

- 1) Check for any damage to the hydraulic power supply and its parts.
- 2) Fill the tank through the breather filter with Shell/Tellus 68 or equivalent fluid.
- 3) Check the nitrogen gas pressure in the accumulator bladder. The pressure should be 35 bar or 66% of the maximum system pressure, whichever is higher. Add nitrogen, if necessary.
- 4) Replace the filter elements with flushing elements. Store the original filter elements in a clean, very clean plastic bag.
- 5) Connect the pressure and return lines to and from the tooling actuator assembly
- 6) Check the motor name plate for the correct line voltages and connect the motor to power. Start the motor and check that it rotates in the proper direction.
- 7) Connect cooling water to the heat exchanger. The required water flow rate is 30 l/min at 2-3 bar.
- 8) Run the hydraulic power supply for at least 6 hours. Vary the flow rate and pressure to thoroughly flush all chips and dirt into the filters. Monitor for leaks and repair.
- 9) Replace the flushing filter elements with the elements removed in step 4.

1-5-12. CONTAMINATION CONTROL

Long term trouble free operation with a minimum of unplanned down time and adequate oil contamination control are linked very closely. It is very important to maintain adequate oil cleanliness. The addition of a system contamination control filter will control oil contamination levels at minimum expense.

The filter should be located such that the flow through the filter is relatively constant and at a low pressure. The junction of the return lines from the tooling actuator and the system relief valve is a suitable location.



Currently, MOOG does not sell filters. Please purchase directly from the filter manufacturer.



Figure 1-15 Flow Pressure Filter

1-6. ELECTRICAL INSTALLATION

1-6-1. GENERAL

Electrical installation includes several phases of work:

- A) mounting the DigiPackIII in a suitable location
- B) determining the correct phasing so the servovalve, tooling position transducer and, possibly, accumulator position transducer may be connected to the DigiPackIII
- C) determining the blow molding machine interface interaction with the DigiPack II and then wiring the machine-DigiPackIII interface
- D) connect the DigiPackIII to electrical power supply from the stable 24VDC

DigiPackIII MOUNTING

The DigiPackIII must be mounted in a location free of vibration, with protection from the environment and most important, located in a position allowing the operator and setup man easy visual and physical access. It is recommended that the mounting be on a swing out panel allowing easy access to the front and back sides of the DigiPack3.

Mounting information is shown in "Figure 1-17". Brackets providing simple panel mounting are included.

 All wiring from the DigiPackIII must be shielded. The shield is to be grounded to the DigiPackIII ground at the DigiPackIII only Any other ground paths may cause damage.

1-6-2. REAR CONNECTOR

The rear connector of DigiPackIII can be detached. When installing the connector, secure with the lock lever. See Figure 1-16.

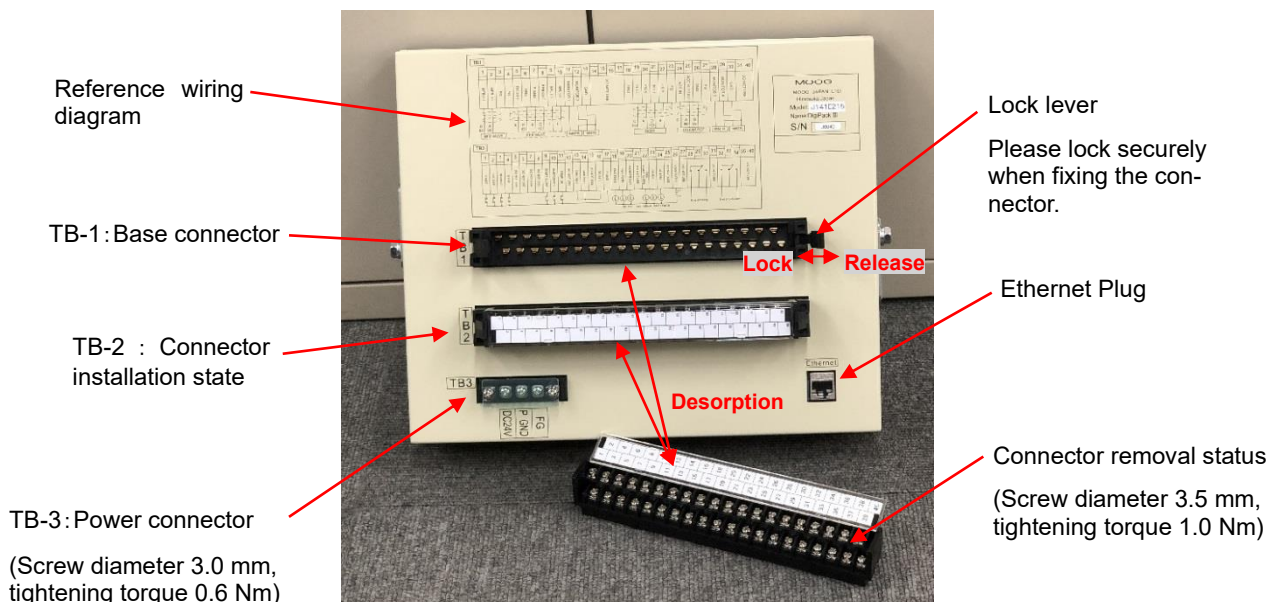

Figure 1-16 REAR CONNECTOR

1-6-3. TB-1, TB-2 WIRING

The wire size for TB-1 and TB-2 are able to use **AWG26 - 16(Recommended AWG 19-18, 0.75 mm²)**, and required using O type or Y type crimp terminal. (Screw diameter 3.5 mm, tightening torque 1.0 Nm).

TB-1 provides the interface between the DigiPackIII and the servovavle, die gap sensor, accumulator position sensor. TB-1 also provides outputs to optional customer monitors MFB Valve current, EFB spool monitor, DCDT input voltage, Accumulator voltage, Position command, these signals can be select at setting display (See 2-4-8.). A schematic of TB- 1 is shown as “Figure 1-19” and TB-1 functions are outlined in the table, “Figure 1-20”.

Phasing definitions for the servovalve, die gap position and accumulator position (if used) transducers are given in “Figure 1-18”.

Some connections to TB-1 are shown in parenthesis, (), in “Figure 1-19”. The parenthesis, (), indicate alternate connection possibilities result from particular directions of motion or phasing determined during the design of the mechanical installation. Phasing requires that a defined direction of motion of the tooling actuator will result from TB-1-1 being negative with respect to TB-1-2; that the output voltage of the die gap position transducer be positive or negative when the die gap is moving in a specific direction; and that the accumulator position transducer output voltage direction be defined when the accumulator is ejecting molten plastic into the die head. Terminal TB-2 is using the external power supply to isolate logic inputs, “Figure 1-21, Figure 1-22”, TB-2 functions are outlined in “Figure 1-23”.

1-6-4. COMMUNICATION AND SSI SENSOR WIRING

The DigiPackIII can be communicate with host computer by **Ethernet**. The connector is using RJ45 socket type for Ethernet (connector name label “Ethernet”). Please refer to Figure 1-17 for connector location. And connector pin assign see below list.

Ethernet connector RJ45 socket “Ethernet”

Pin No.	Signal	Connection
1	TD+	
2	TD-	
3	RD+	
4		
5		
6	RD-	
7		
8		

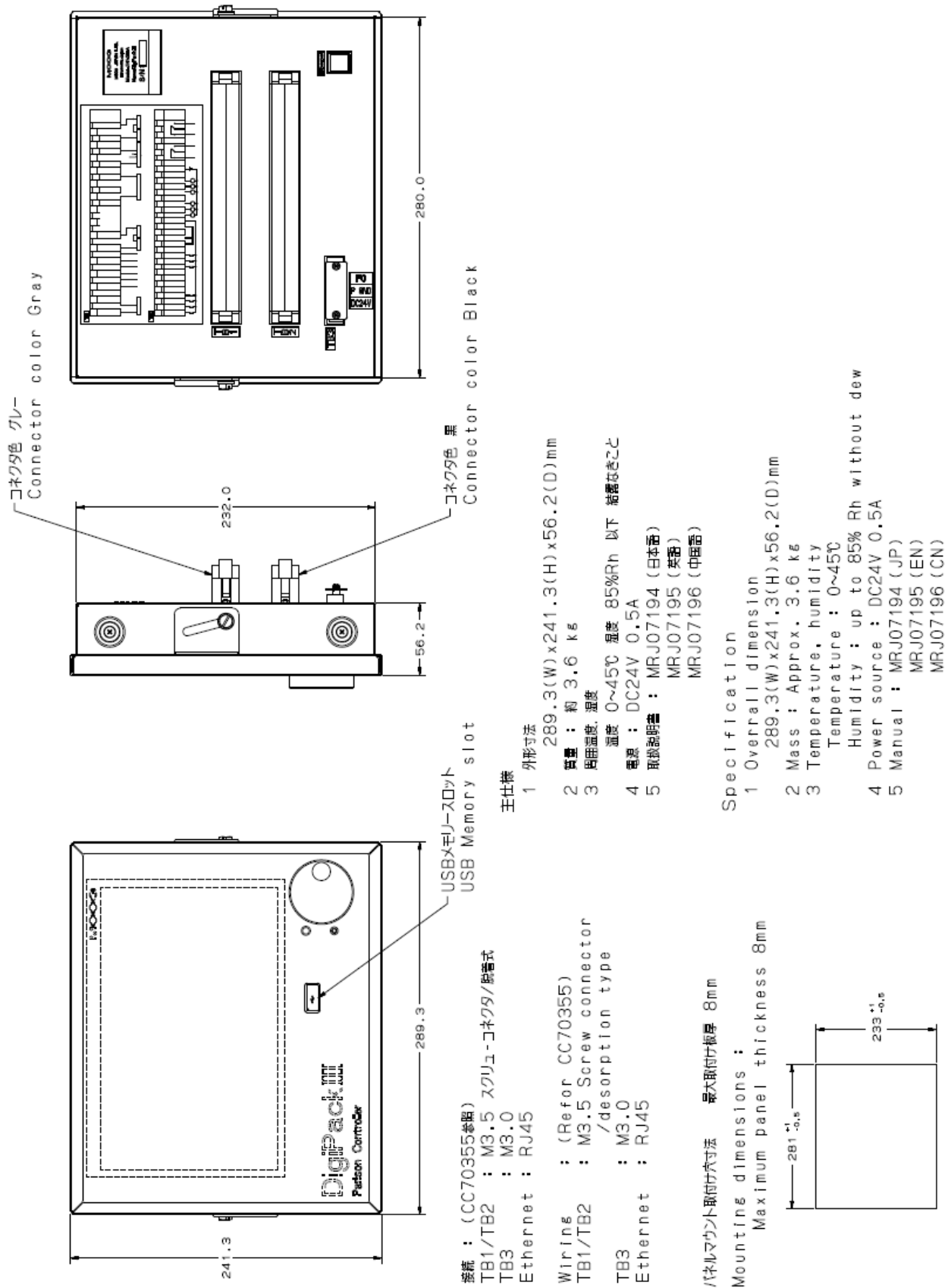

Figure 1-17 DigiPack III Installation Drawing

REAR PANEL CONNECTIONS

PHASING TB-1: Analog I/O Terminals (Moog Product and Transducers)

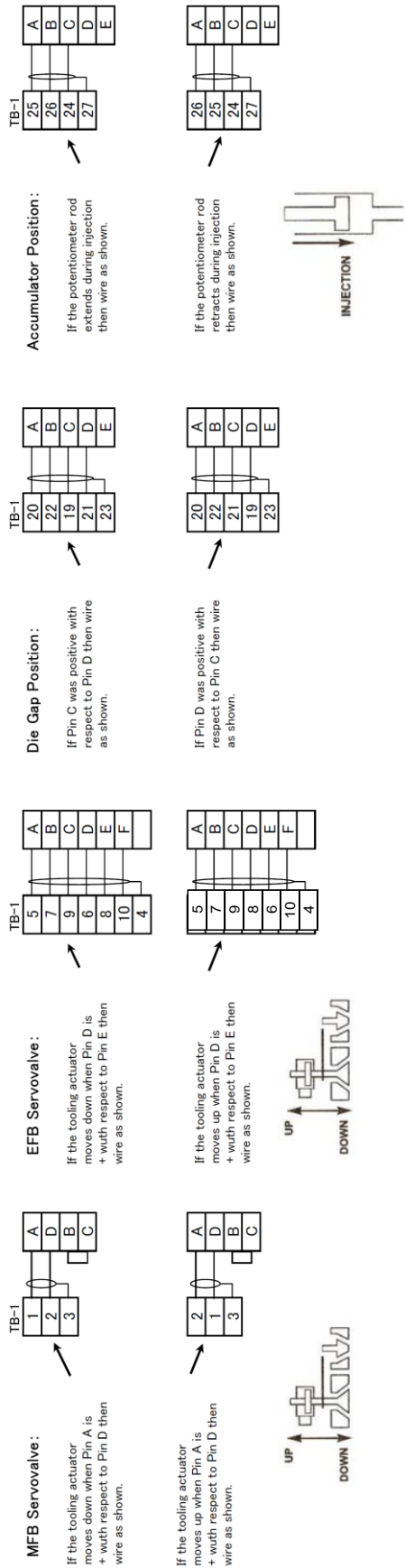

Figure 1-18 Servo Valve and Transducer Phasing

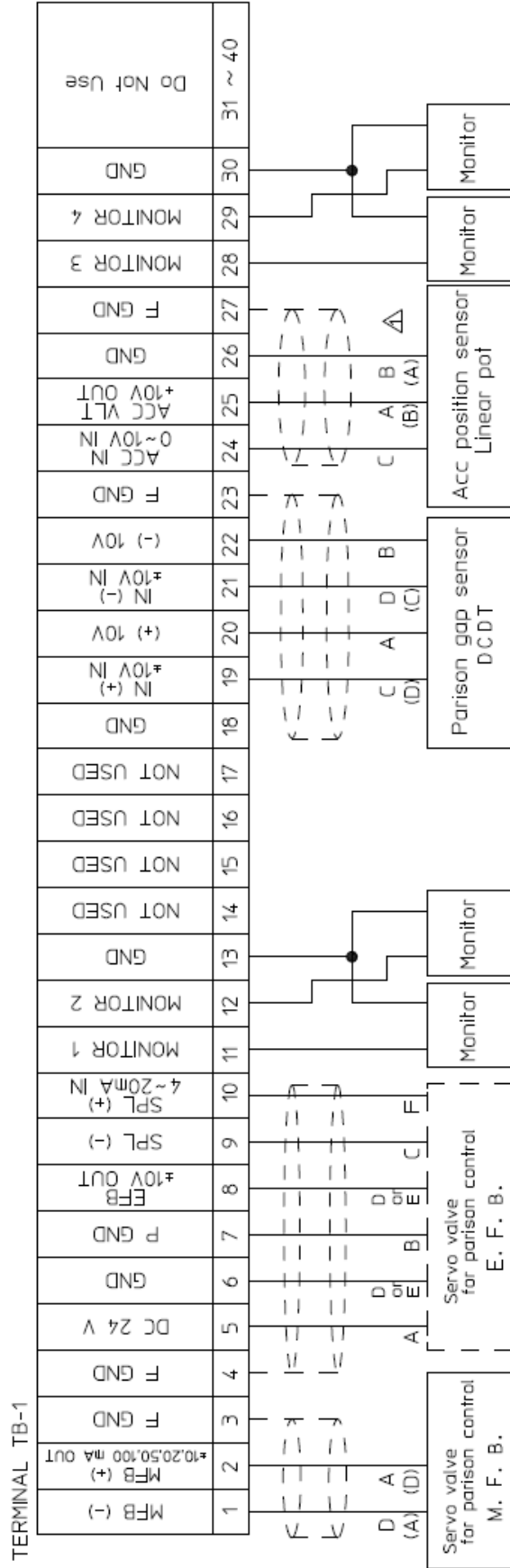

Figure 1-19 TB-1 Connections

TB-1: Analog I/O Terminals (Moog Production and Transducers)

Term No.	Name	IN/OUT	Function	Comments
1	-MFB Signal	OUT	Pin A or D, B to C, MEB Servo valve	(MFB) Mechanical Feedback
2	+MFB Signal	OUT	Pin A or D, B to C, MEB Servo valve	Connection A to D or D to A allow phase reversal
3	F GND(Cable Shield)		Cable Shield ground, MFB Servo valve	Do not ground the shield at the servovalve
4	F GND(Cable Shield)		Cable Shield ground, EFB Servo valve	Do not ground the shield at the servovalve
5	24V DC	OUT	Pin A, EFB Servo valve	(EFB) Electrical Feedback Valve Power, Max 1.5A available
6	GND	OUT	Pin E or D, EFB Servo valve	The polarity is reversed depending on the connection of pin D / E
7	P GND		Pin B, EFB Servo valve	
8	EFB Signal	OUT	Pin D or E, EFB Servo valve	EFB Signal : ±10V OUT
9	Valve Spool(-)	IN	Pin C, EFB Servo valve	Spool Signal : 4-20mA
10	Valve Spool(+)	IN	Pin F, EFB Servo valve	
11	Monitor 1	OUT	Monitor Out 1	±10 V DC OUT. Signal selectable
12	Monitor 2	OUT	Monitor Out 2	±10 V DC OUT. Signal selectable
13	GND		Monitor Ground	Ground for Monitor 1 and 2
14	NOT USE			
15	NOT USE			
16	NOT USE			
17	NOT USE			
18	GND			
19	DCDT IN (+)	IN	Pin C or D : DCDT Feedback signal (+)	(DCDT) Parison core position feed back sensor
20	+10V DC	OUT	Pin A : DCDT Power voltage (+10V)	The level of the feedback signal changes depending on the type of DCDT (maximum: ± 10 V)
21	DCDT IN (-)	IN	Pin D or C : DCDT Feedback signal (-)	The polarity is reversed depending on the connection of pin C / D
22	-10V DC	OUT	Pin B : DCDT Power voltage (-10V)	
23	F GND(Cable Shield)		Cable Shield ground, DCDT	Do not ground the shield at the Actuator or DCDT
24	ACC IN	IN	Pin 2, Potentiometer	(ACC Pot) Accumulator position feed back sensor
25	ACC VLT	OUT	Pin 1 or 3, Potentiometer	Available accumulator type: Internal resistance 1 kΩ or more
26	GND		Pin 3 or 1, Potentiometer	
27	F GND(Cable Shield)		Cable Shield ground, Accumulator	Do not ground the shield at the Accumulator
28	Monitor 3	OUT	Monitor Out 3	±10 V DC OUT. Signal selectable
29	Monitor 4	OUT	Monitor Out 4	±10 V DC OUT. Signal selectable
30	GND		Monitor Ground	Ground for Monitor 3 and 4
31~40	NOT USE			

Figure 1-20 TB-1 Functions

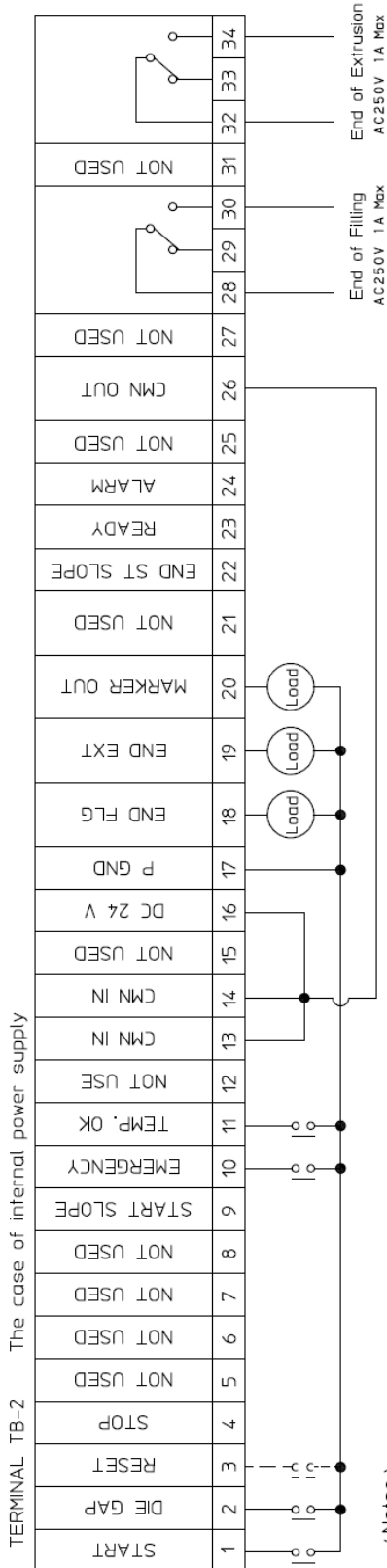

Figure 1-21 TB-2 Connection with Internal Logic Supply

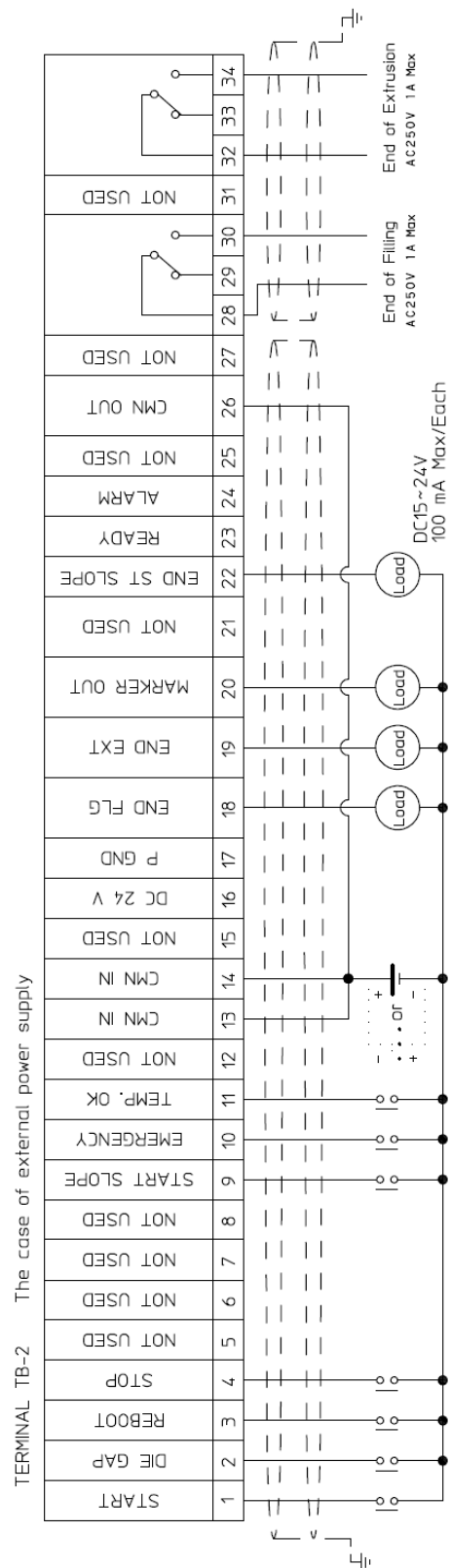

Figure 1-22 TB-2 Connection with External Logic Supply

TB-2: General I/O Terminals

Term No.	Name	IN/OUT	Function	Comments (Refer Fig1-20, 1-21)
1	IN1 START	IN	Command for Cycle Start	Enable machine cycle start.
2	IN2 DIE GAP	IN	Command to keep the tooling die gap at the set Die Gap value until IN1 START	It is valid at any time by continuous mode. Cycle is stops Accepted only at injection completion state (END EXT) at ACC mode
3	IN3 REBOOT	IN	Reboot switch for controller.	Not accepted during machine cycle
4	IN4 STOP	IN	Command for Stop operation	Cycle stop, hold at current position
5~8	NOT USE			
9	IN9 START SLOPE	IN	A command to move the core from the current position to the position of the first point. The movement speed is set on the screen.	Maintain position until start after moving completes. Not accepted during machine cycle
10	IN10 EMERGENCY	IN	Servo OFF command. (E-Stop)	When it is High, the servo valve signal is stopped. Because it is an emergency stop, accept at any time ON = Emergency state
11	IN11 TEMP. OK	IN	Temperature rise completion confirmation.	When this signal is High, the servo valve signal is stopped. ON = Temp not rised
12	NOT USE			
13	INPUT COM.		Common for Digital Input (Isolation)	Pin 13-14 is internally connected. Both Sink/Source support. For details see manual page 25
14	INPUT COM.			
15	NOT USE			
16	24V DC		Digital signal power supply for both IN/OUT	Maximum current out : 3.0A
17	P GND			
18	END FLG.	OUT	ON at End of Filling. Maintain until it falls below the position of End Filling	With this signal, the filling of the accumulation is stopped
19	END EXT.	OUT	ON at End of Extrusion.	With this signal, the injection of the accumulation is stopped
			In Continuous mode: ON until the next start. In Accumulator mode: ON while the accumulation position is smaller than the injection completion position	※ In the case of Accum mode 1% hysteresis (injection & filling)
20	MARKER OUT	OUT	Marker output signal. Output at the specified marker point	Pulse width 200 msec
21	NOT USE			
22	END ST SLOPE	OUT	At start slope input, ON at movement completion, maintain until IN1 start input	
23	READY	OUT	Turn on when the start condition is set	When this signal is ON, controller can receive the start signal.
24	ALARM	OUT	When both IN10 and IN11 are High and output (OFF=alarm state)	※ This is not an interlock. Just inform to the host controller
25	NOT USE			
26	OUTPUT COM.		Common for Digital Output	Both Sink/Source support. For details see manual page 25
27	NOT USE			
28	EOF Relay COM	Relay	END OF FILLING Relay Common	Relay output, AC250V, Maximum 1A
29	EOF Relay B		END Relay Contact B (NC)	
30	EOF Relay A		END Relay Contact A (NO)	
31	NOT USE			
32	EOE Relay COM	Relay	END OF EXTRUSION Relay Common	Relay output, AC250V, Maximum 1A
33	EOE Relay B		END Relay Contact B (NC)	
34	EOE Relay A		END Relay Contact A (NO)	
35~40	NOT USE			

Figure 1-23 TB-2 Functions

1-6-5. TB-2 I/O CIRCUITRY

Input _____

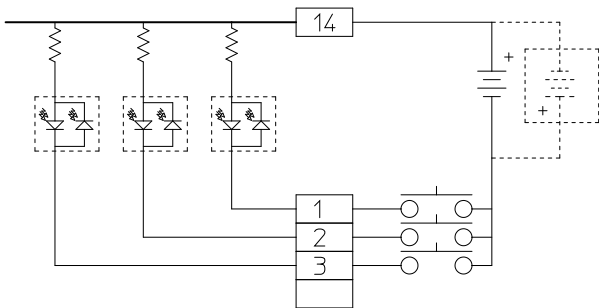

Figure 1-24 Input use external Power supply

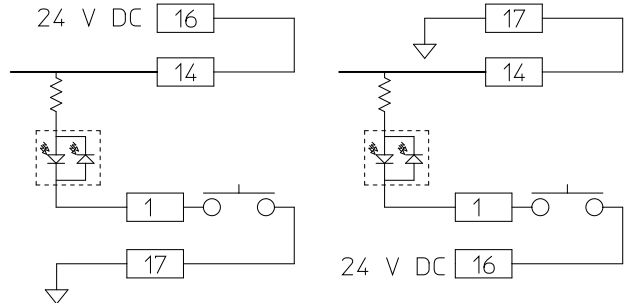

Figure 1-25 Input use internal Power supply

All DigiPack III I/O can be uses both POSITIVE/NEGATVIE LOGIC

DigiPack III can be used external and internal power supply. And provide isolated inputs.

The external power supply has an output 24VDC.

The contacts used must have very low contact resistance over a long life time.

Extreme care is required when wiring to insure that ground loops do not exist. Ground loops can cause damage to the DigiPack III and other electronic equipment. Ground loops can also cause erratic operation of the entire blow molding machine.

Output _____

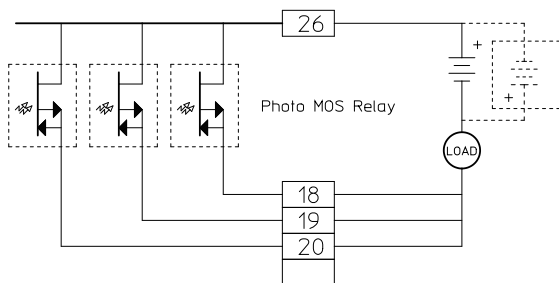

Figure 1-26 Output use external Power supply

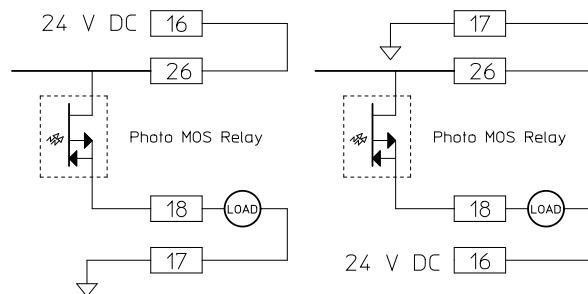

Figure 1-27 Output use internal Power supply

DigiPack III's output circuits use Photo MOS Relay to provide isolation from the external circuitry.

The maximum voltage and current output to each load terminal (TB-2, 18, 19, 20, 22, 23 and 24) is 24VDC and 100 mA MAX/each.

1-6-6. TB-3: POWER SUPPLY

The wire size for TB-3 is able to use **AWG17 – 16, 1.75 mm²**, and required using O type or Y type crimp terminal. (Screw diameter 3.0 mm, tightening torque 0.6 Nm).

Term No.	Name	Specification
DC24V	Power Supply 24V	24V DC Input 0.5A min – 3.0A max * Required install Fast blow Fuse. * No ripple required, Max +/-10 %
P GND	Power Supply 0V	0V (for DC 24V)
F GND	Earth	



There is protection that does not break down with reverse wiring, but please be careful because input of high voltage will damage the circuit.

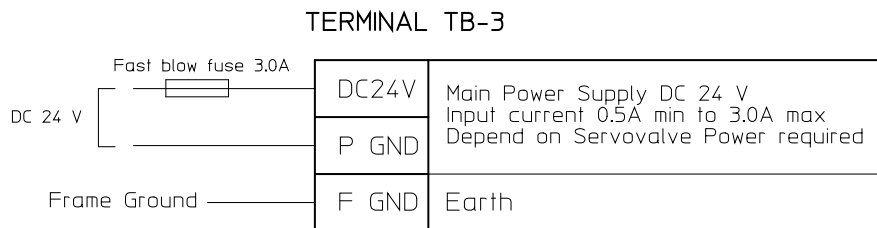

Figure 1-28 Power supply Connections

1-6-7. NOISE AND GROUND ISOLATION

In any location there is always the potential for electrical noise interference and multiple ground paths. Electrical noise can cause erratic system operation and is very difficult to find and isolate, ground loops also cause unexpected operation as well as burn out components. In addition, mains voltage stability can sometimes be questionable.

An isolation transformer between the mains and DigiPackIII can provide some relief from noise, ground loops and wandering mains.

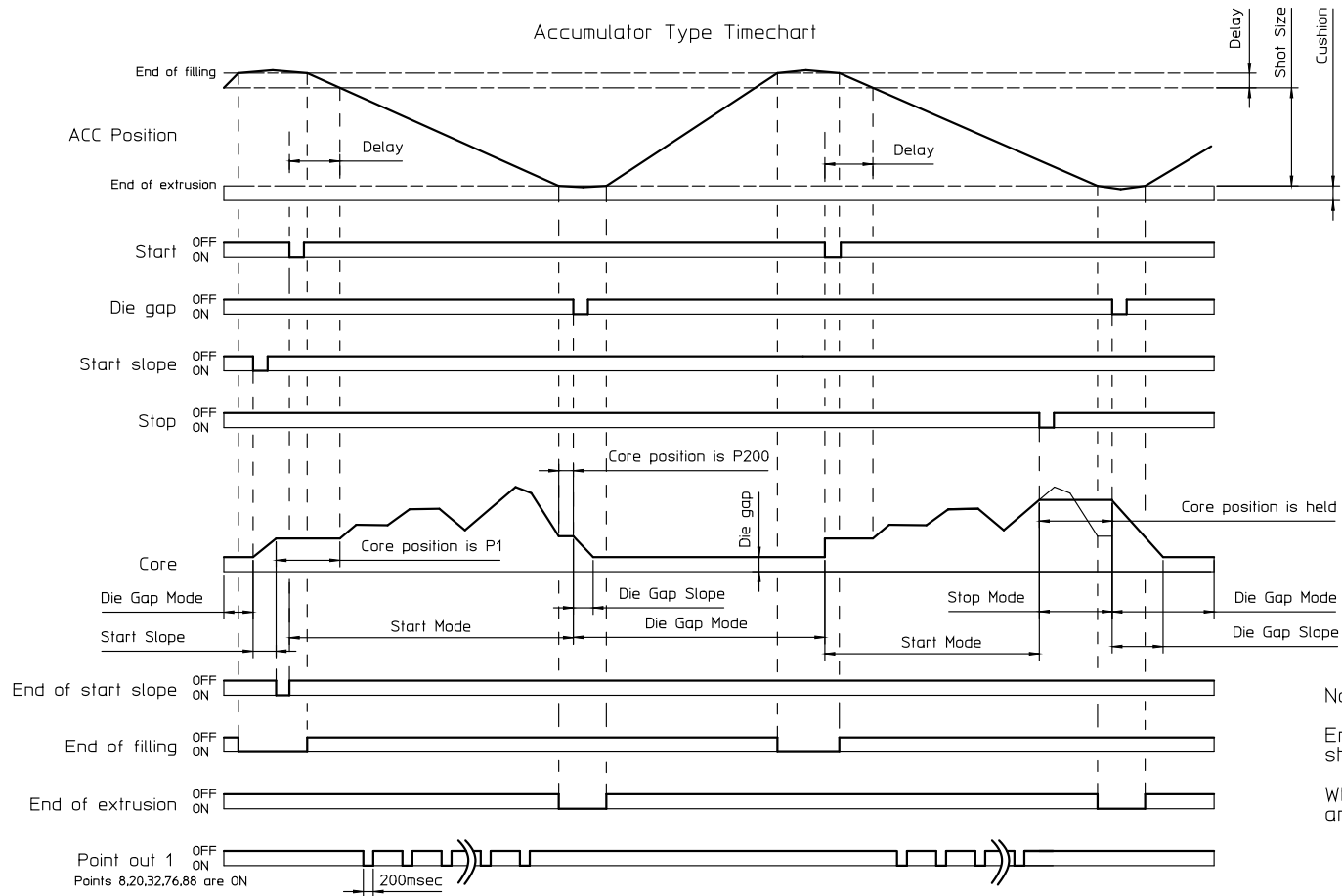
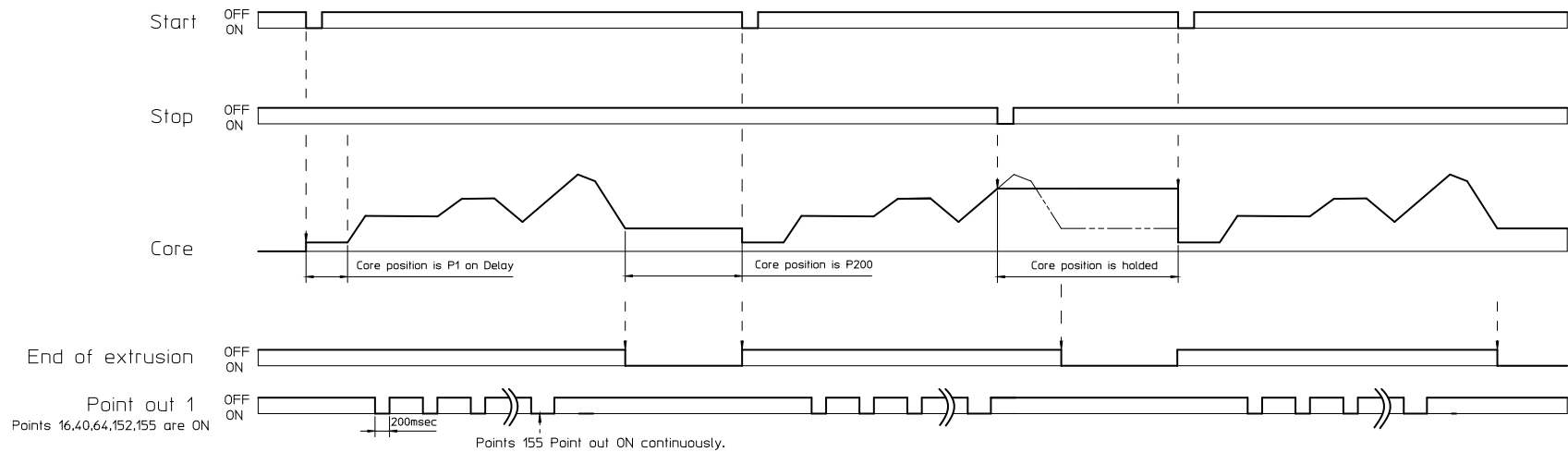

Figure 1-29 Accumulator Machine Timing chart

Continuous Type Timechart



Note:

Emergency(DI10) and Temperature OK(DI11) should be always OFF during control.
When one of them turns ON, control stop and the output to the Servo valve also stop.

Figure 1-30 Continuous Machine Timing chart

1-7. CALIBRATION OF TOUCH SCREEN

Calibration of the touch screen has already been completed at the time of product shipment, so basically no user setting is necessary. Here is explain that the readjustment method when there is an error in the calibration of the touch screen by some reasons. (If there is an error in the calibration of the touch screen, the touch area corresponding to the display button will shift, so it will not react even if you touch the display button.)

 If the readjustment becomes frequently necessary, it seems that some trouble has occurred on the touch screen. In that case we recommend that you submit it for repair.

- Step 1: While DigiPackIII powered on, digital signal is continuously input for 3 seconds or longer to TB-2-8 (this channel displayed as Do not use).
- Step 2: DigiPackIII will be automatically restarted and the calibration screen as shown in Figure 1-31 will be displayed. Touch the "Calibration" button. (At this time, since the calibration information is reset, "Calibration" button can be pressed)
- Step 3: Since Figure 1-32 is displayed, touch all the "+" signs surrounded by the red frame square in the corner. If you press the wrong place to push, the calibration will fail and the screen will stop responding. In that case, please turn on the power again, return to step 1 and try again.
- Step 4: If the calibration is successful, display will return to Figure 1-31, Restart the controller and finish.

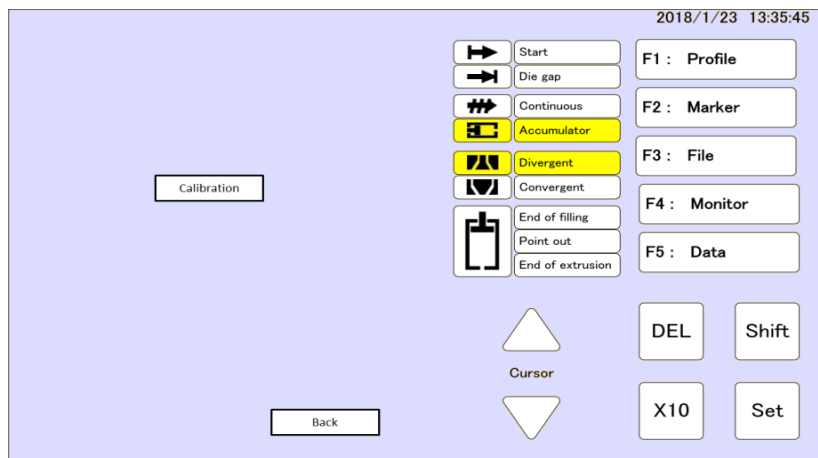

Figure 1-31 Touch screen Calibration

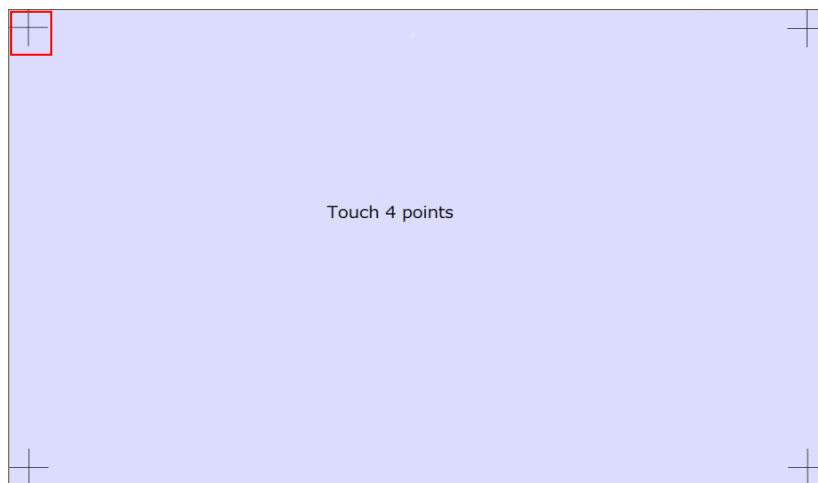

Figure 1-32 Touch screen calibration display

1-8. DigiPackIII front panel

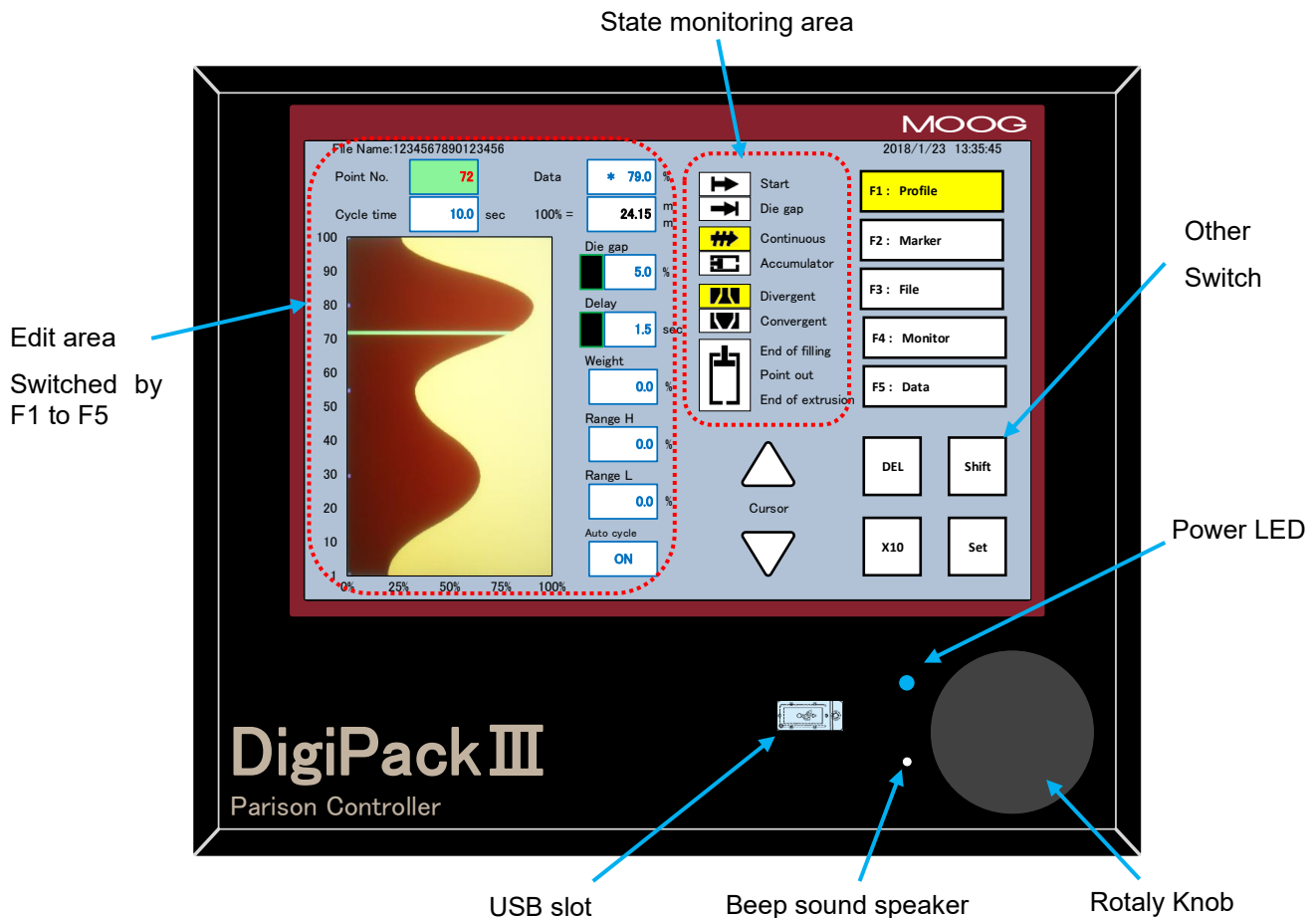

Figure 1-33 DigiPackIII Flont panel

OPERATIONS CONTROLS

The operator will setup and monitor the parison wall thickness program using the display switches and Rotaly knob on the DigiPackIII’s front panel, shown in “Figure 1-33”

Beep sound

A beep sounds when parameters and keys in the screen are selected. Also, if an error occurs at startup and normal startup can not be performed, A beep sounds ON/OFF is repeated continuously.

Power LED

It lights up with 24 VDC being supplied. Also, if an error occurs at startup and normal startup can not be performed, ON/OFF is repeated continuously.

All of the functions normally required to program the parison and machine are available on the front panel.

INPUT FUNCTION SELECTION AND VALUE

- Rotaly Knob Used to enter the value of various functions. Rotation in a clockwise
- X10 Increases the sensitivity of the Rotaly Knob by a factor of 10
- SET Push to set value
- DEL Invalidates the set profile data and changes it to interpolation data.

SHIFT	While pressing "SHIFT" is active, the screen called by the F1 to F5 switches becomes the setting screen. If you push this switch again or select one of F1 to F5 setting screen, "SHIFT" becomes inactive. *Refer to 1-2-6. for protection of setting screen transition
Cursor $\triangle \nabla$	Used to scroll the items on the LCD in the direction indicated by the triangular shape



Highlights are used to indicate the action function or its value to the operator. You can change the value of the highlighted parameter by turning the rotary knob or inputting from the numeric keypad. *The numeric keypad is displayed on the screen after touching the same parameter again or turning the rotary knob after specifying the parameter. For details, refer to section 2-3-2.

STATE MONITORING AREA

In the status monitoring area shown in Figure 1-33, it is used to indicate the status of the following functions.

Start	Lights when the cycle Start signal is received.
Die Gap	Lights when the Die Gap signal is received and "DIE GAP" on the LCD is lit
Continuous	Lit when the "Continuous Extrusion" machine type is selected
Accumulator*	Lit when "Accumulator" machine type is selected
Divergent	Lit when "Divergent" die gap tooling is selected
Convergent	Lit when "Convergent" die gap tooling is selected
End of Filling	Lights at the end of the accumulator filling stroke
Point Out	Lights when each Marker point is reached
End of Extrusion*	Lights at the end of the accumulator extrusion stroke (Cushion)

SWITCH OF F1 TO F5

It is used to select the function screen displayed in the editing area shown in Figure 1-33. The contents of the function are as follows.

F1 Profile	Controls the parison wall profile and other related functions. (When start up the controller, move to this screen first)
F2 Marker	Set the program point markers. And set the slope(Speed) that do to Die gap and start position. Internal clock time setting. PURGE/TOOLING core opening setting
F3 File	Controls the container wall thickness storage functions
F4 Monitor	Indicate the digital I/O, current value of servovalve input current and core position. Manual operation is also done on this screen.
F5 Data	Displays the profile point and related function data
SHIFT→F1	SET UP Mode - Provides die gap tooling and other machine related set up functions
SHIFT→F2	Signal assign to Monitor Analog output
SHIFT→F3	Delete and Backup/Restore the storage data.(Backup/Restore for data in USB memory)
SHIFT→F4	Machine setting setup
SHIFT→F5	Communication parameter setting of Ethernet.

1-9. TOOLING SYSTEM SETUP

1-9-1. GENERAL OF SETUP



The Mechanical and Electrical installation must be finished before the Dig Gap Tooling position control system can be set up. In addition the, hydraulic system must have been flushed for at least 24 hours.

The Die Gap Tooling position control system setup involves several steps:

- 1) The Machine setup in the DigiPackIII display (SHIFT→F4) must be set to match various options determined by the blow molding machine and tooling head type.
- 2) The correct tooling type selection, Convergent or Divergent, must be determined. This will be determined by which portion of the tooling moves, the die or mandrel, as well as its internal shape.
- 3) The DigiPackIII must know if the blow molding machine is a Accumulator or a Continuous molding machine.
- 4) The working Die Gap end positions, closed and maximum open, must be set.
- 5) The responsiveness of the Die Gap Tooling position control system is measured and optimized.

When finished with the Die Gap Tooling system setup, the blow molding machine will be ready to be programmed for production containers.



The hydraulic pressure must be lowered during the setup procedure or the die gap tooling may be damaged.

1-9-2. MACHINE SETTING

After confirming the mechanical and electrical connection completely, turn on the DigiPackIII. However, please do not apply hydraulic pressure yet here.

The LCD of DigiPackIII gets brighter and [F1 Profile] is displayed via the startup screen. Next, press the [SHIFT] → [F4] key in that order to reflect the machine settings such as language, servo valve type, continuous type machine or accumulator type machine.

1.9.2.1. MACHINE SETTINGS (SHIFT→F4)

At the DigiPackIII display “SHIFT -> F4” (“Figure 1-34”) is Setting for Machine setting. Set these parameters according to Machine type, these parameters should setting before start setting any parameter of tooling and accumulator. (Accumulator setting only accumulator machine)

The settings required now are:

- 1) Machine type - Either Continuous or Accumulator
- 2) Servovalve type - Either mechanical feedback, MFB, or electrical feedback, EFB
- 3) Valve current - If selected MFB type, this parameter can be selected current level 10, 20, 50 or 100 mA



Depending on the setting of MFB and EFB, the output terminal changes. (The output terminals of MFB/EFB are located in TB-1.) The Servovalve type that not set is fixed to "0" mA or "0" V, if no output signal and the actuator does not operate, Please review the machine setting.

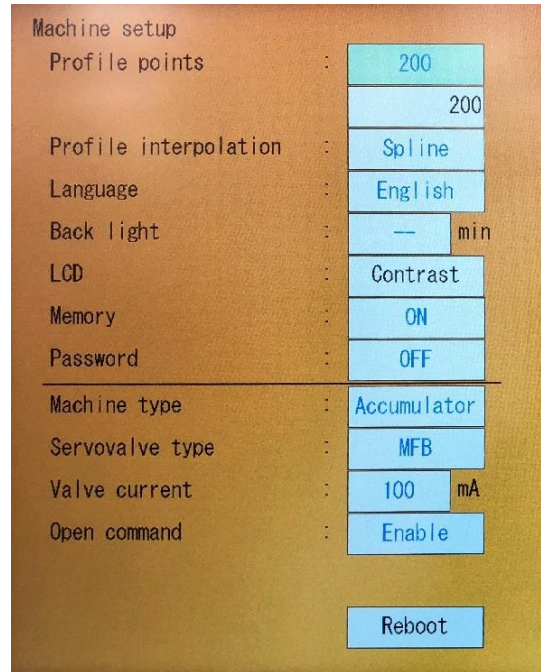

Figure 1-34 Machine setup display (SHIFT→F4)

“Figure 1-35” defines all of the settings.

Function name	Setting			
Profile points	10/20/30/50/100/200			
	Custom			
	Any value between 10-200			
Profile interpolation	Straight			
	Spline			
Language	English	Chinese	Japanese	
Back light (min)	5	10	30	-- (no screen saver)
LCD	Contrast. Knob CCW : dark, Knob CW : bright			
Memory	ON		OFF	
Password	ON		OFF	
Above 7 parameters are updated always				
Machine Type	Continuous		Accumulator	
Servo valve type	MFB		EFB	
Valve current (mA)	10	20	50	100
	-- (*Note)			
Open command	Disable		Enable	
The above 4 parameters are updated by pressing the switch in the order of [Reboot]->[SET], by being restarted				
*Note) When [Servo valve type] is set to [EFB], it automatically becomes ± 10 V output.				

Figure 1-35 Machine setting Functions



It is necessary to execute Reboot whenever you change the setting. When moving to another screen without Reboot, the parameter returns to its original value. When you press [Reboot] → [SET], DigiPack III will be restarted. Do not apply hydraulic pressure when executing [Reboot].

1.9.2.2. MACHINE SETTING (SHIFT → F4) FUNCTION

Profile points	It is possible to specify the number of set points in the profile display (F1) from [10/25/30/50/(*)100/200 / Custom]. When [Custom] is specified, it is possible to specify the number of profile points freely between 10 and 200 points.
Profile interpolation	Sets a interpolation (*)Straight or Spline on the profile display (F1)
Language	Language – ((*)English/ Chinese / Japanese) Sets the language used on the LCD Display
Back light (min)	Sets the timer of screen saver. 5, 10, (*)30 min or non screen saver.
LCD	Adjust the screen brightness. Knob CCW : dark, Knob CW : bright
Memory	Select actual feedback line indicated on profile display. (*)ON : Show, OFF : Not Show
Password	Sets to enable or disable of password protection at the migration of setting screen. (* ON: Enabled, OFF: Disable * When disabled, there is no protection for setting screen transition.
Machine Type	Machine type – Accumulator or (*)Continuous
Servo valve type	Servo valve type – EFB or (*)MFB
Valve current	Valve current of MFB type – 10, 20, 50 or (*)100 mA
Open command	Cursor move admission to Open command on Monitor display (F4) Enable or (*)Disable

Marked as (*) is initial setting with new DigiPackIII shipped.



When “Profile Points” is changed, if the value is not specified in the original profile at the final point of the new profile (for example, 25th points of when specified 25 points) If it was interpolated value, the new 25th point in the profile is specified as the height "0". Also, when the number of profile points is increased (Example 100 to 200), the profile of the newly added part is specified as the height "0". See Figure 1-36

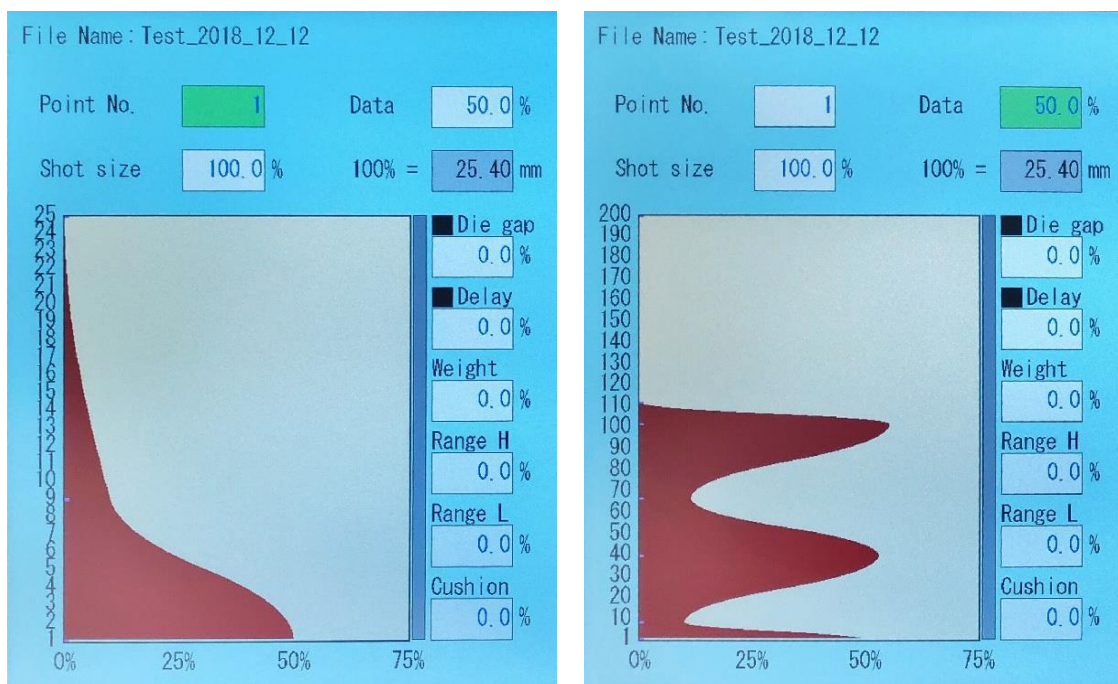

Figure 1-36 Example of profile points change

1-9-3. SET UP PROCEDURE

To go to Set Up mode press “SHIFT” then press “F1”. The Set Up mode screen appears as shown in “Figure 1-37”.

Three words [DCDT], [Accumulator], and [Gain] are displayed on the left side of the screen. By selecting them, you can set DCDT, accumulator and gain value respectively. The highlighted word (in this case [DCDT]) indicates the setup screen that will transition when you press [SET]. However, [Accumulator] is displayed only when it is set to accumulator type mode at [Machine] setting ([SHIFT]→[F4]).

Note that the [DCDT], [Accumulator], and [Gain] screens have a button as "Back" under the setup parameters of the screen. If [Back] is highlighted and you press [SET] or directly touch [Back] on the screen, the display returns to the setup screen (Figure 1-37).

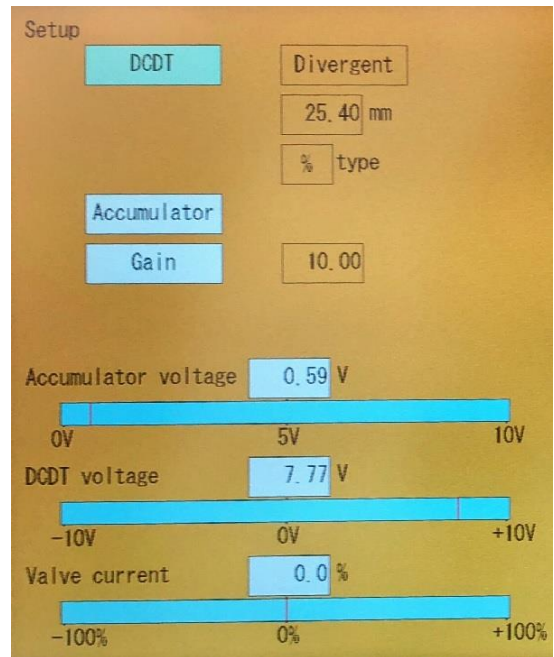

Figure 1-37 Setup screen

1.9.3.1. DCDT SETUP

To go to the [DCDT setup] screen, press [SET] when [DCDT] is highlighted in Figure 1-37 or directly touch [DCDT] on the screen.

The screen shown in Figure 1-38 is displayed.

CONVERGE/DIVERGE SETTING

The selection between Converge and Diverge tooling designs implies that the selection between Converge and Diverge is a simple one. This is not necessarily true.

If the Converge or Diverge tooling uses a moving mandrel (inner part), then simply set Converge or Diverge as dictated by the tooling design.

However, if the Converge or Diverge tooling uses a moving die (outer part), then the other tooling type name must be used. For example, if the tooling design is Converge and the die is the moving part, the proper tooling selection for the DigiPack III is Diverge. Example below.

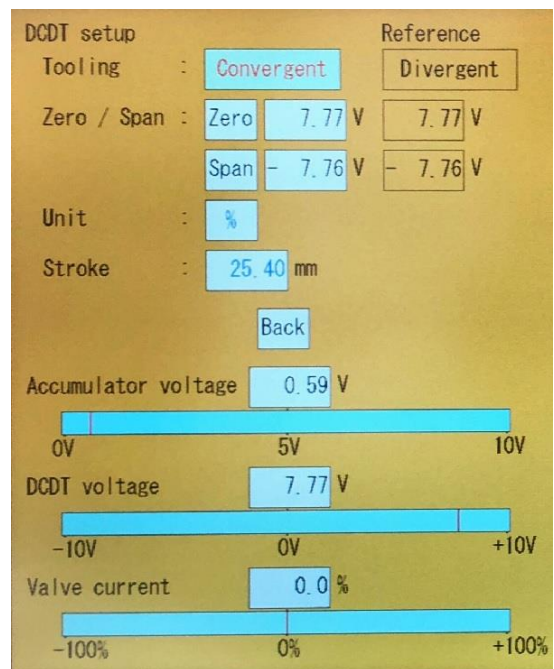
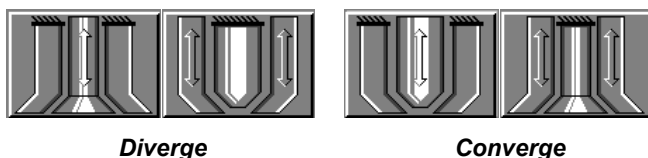

Figure 1-38 Die Converge/Diverge Setup



An alternate: if the tooling actuator moves in a downward direction to make thicker parison walls, then select Diverge. If the tooling actuator moves in an upward direction to make thicker parison walls, select Converge as the tooling type selection.

CONVERGE/DIVERGE SELECT

At the [DCDT setup] screen with Converge highlighted. (Figure 1-38) Select DIVERGE or CONVERGE by rotating the ROTALY KNOB in a cw or ccw direction. When the selection is made, push Set.

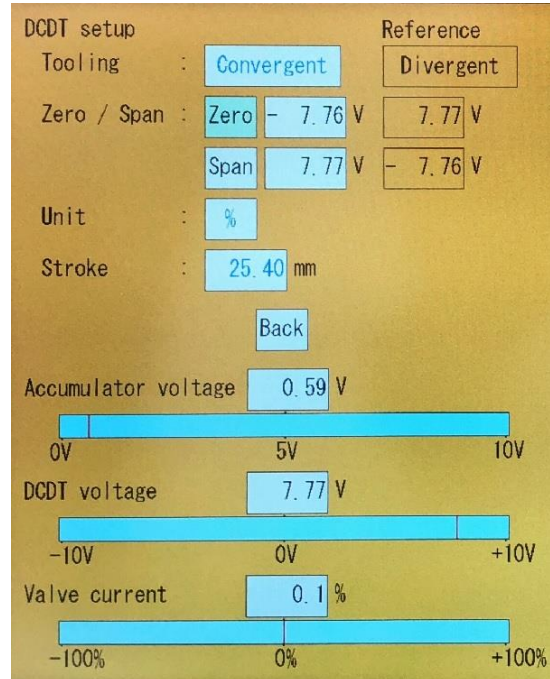

Figure 1-39 Die Gap Setup



The currently set values and file values (Reference) for Figure 1-39 and Figure 1-38 are displayed. The value (Reference) of the file shows the setup value saved in Digi-Pack III memory using [F3:File]. For machine protection, these data are not rewritten directly from the file as production data and are displayed as reference values (Reference).

CORE

In this screen, "Figure 1-39", under the heading Zero/Span, Zero is highlighted. Zero is the Die Gap closed position. If the tooling installation includes a Tooling Motion Stop then it must be temporarily positioned so the stop does not interfere with the tooling motion.

Note that the Valve current (or spool monitor) indicator may show a Valve current (spool position) indication that is continuously and rapidly moving back and forth over a band of as much as 25% of the indicated range. If there is a continuously moving indication of more than 5% then the Die Gap transducer connection to TB-1 should be changed to conform to the schematic show in "Figure 1-40".

Rotate the ROTALY knob to make the tooling move in the Die Gap closed direction (CCW). When the ROTALY Knob is turned, the Valve current indicator will move slightly and then return to zero or nearly zero when the ROTALY KNOB is stopped. The DCDT voltage indicator will indicate the changed Die Gap position.

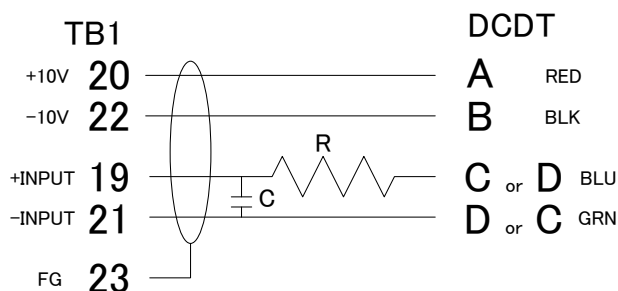

Figure 1-40 DCDT Noise Filter

ZERO

Continue to move the Die Gap towards its closed position (Rotaly knob CCW) while watching the Valve current indicator. At some point the Valve current indication will not return to zero, but will increase with further rotation of the ROTALY knob, while the Die Gap does not change position. Increasing Valve current without Die Gap motion indicates that the Die Gap has closed (or has run into a motion stop).

Then slowly rotate the ROTALY knob in the reverse (CW) direction while watching the Valve current indicator until the Valve current reaches Zero or the Die Gap indicator moves slightly.

Now turn the ROTALY knob in the original direction until the motion just stops and the Valve current indicator shows slightly increasing current. The Die Gap has just reached its closed position.

Push SET. The value of the current DCDT voltage is reflected as the position of [Zero] (0% position), and the highlight moves to [Span]. (Figure 1-41)

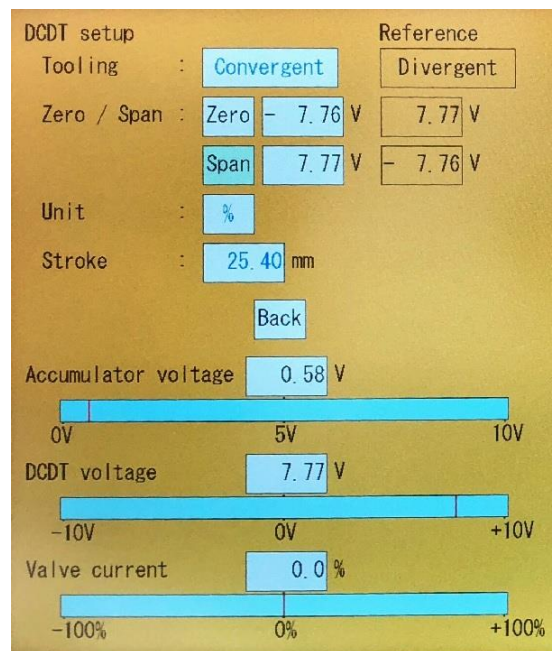

Figure 1-41 Die Gap Span Setting

SPAN

When zero setting is completed, the highlight will indicate [Span] (Figure 1-41). [Span] is the maximum value of the die gap opening (100% on the profile). The die gap core designer checks the [DCDT voltage] indicator and turns the rotary knob clockwise (CW) to the value of the opening to be specified and set it. At this time, when the servo valve current starts to move greatly, it means that it has reached mechanical stop position. In that case, rotate the rotary knob in the opposite direction again and look for where the servo valve current returns to near the center.

When the required die gap maximum opening has been reached, press [SET] and finish setting the span. The highlight moves to [Unit].



If you do not do zero and span on the DCDT setting screen, do not move the cursor by touching the [SET] key. If [SET] is pressed while [Zero], [Span] is highlighted, the current DCDT position will be reflected to zero and span. To move highlighted parameter, please use the up / down (Δ / ∇) key or directly touch the desired parameter.

Unit and Stroke

When [Span] is highlighted, touch [SET] or the cursor down key, the cursor will move to [Unit] (% or mm). “%” is set to 100% as the distance indicated in [Stroke] and displayed on the profile screen as reference. “mm”, set the profile directly in mm based on Span setting. Select the desired unit with the rotary knob and press [SET]. The value of [Stroke] sets 0 to 100% stroke length of DCDT. Measure 0-100% movement amount with a ruler and input it. The value set here, 100% = Stroke (mm) is displayed on the profile screen as a reference for the die gap opening.

After completing the setting, move the cursor to [Back] as shown in Figure 1-42 and press [SET] or directly touch [Back] on the screen to move up one screen.

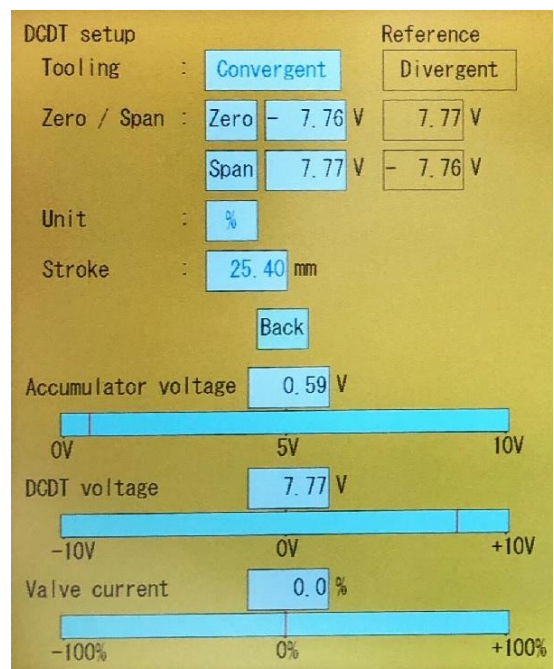

Figure 1-42 Back

1.9.3.2. GAIN SETUP

Use Up / Down cursor to move to [Gain] (Figure 1-43) and press [SET] or touch [Gain] on the screen directly, the screen will shift to Figure 1-44 screen. In [Gain], adjust the speed and stability of die gap core control actuator. At this point, it is necessary to increase the hydraulic pressure to the correct value.

At Figure 1-44 use the up and down cursor on the screen to move to [Move] or touch [Move] on screen directly to select. Turn the rotaly knob left or right and observe the DCDT voltage indicator. If it is normal, the indicator will move right and left smoothly according to the movement of the rotaly knob. If the movement is awkward (poor tracking), return to the setting of the gain, increase [Gain] by about 25% and check the operation again by [Move]. If noise behavior is seen, move to [Gain], reduce it by about 25%, and confirm the operation with [Move] again. Repeat this until the response becomes good, move the cursor to [Back], press [SET] or directly touch [Back] on the screen to move to the previous screen.

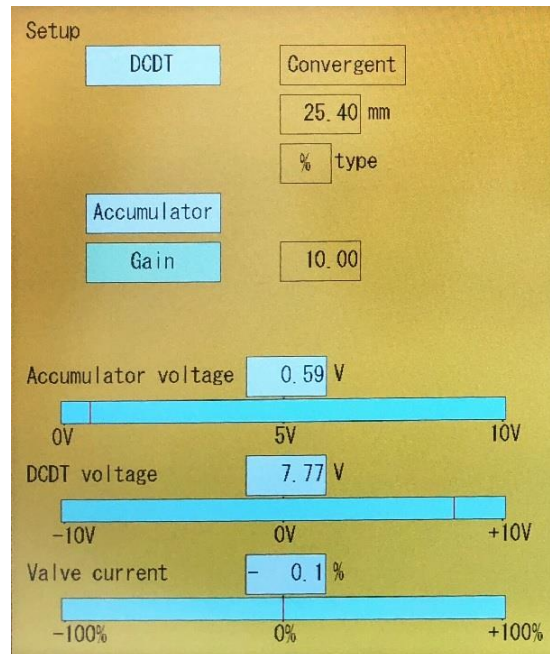

Figure 1-43 Gain select

* The [Gain] parameter reflects the value in real time according to the rotation of the rotary knob. Therefore, the numeric keypad is not displayed. Also, [SET] for confirmation is unnecessary.

* When an oscilloscope is available, monitor the movement of the core with [MOVE] while monitoring between 19 of TB-1 and 21 of TB-1.

This completes the setup of the continuous blow molding machine.

A NOTE REGARDING CORE STROKE AND ZERO

The value displayed in [Reference] is the value saved on the F3 screen. Because the reference numerical value directly affects the specification of the machine, it does not reflect as it is at the time of file loading (there is a possibility that the machine may break down). These numbers are displayed as Reference in order to see how they were set in the loaded configuration file. This will be displayed to allow customers to switch products quickly while minimizing the switching time from the end of production to the start of the next new production

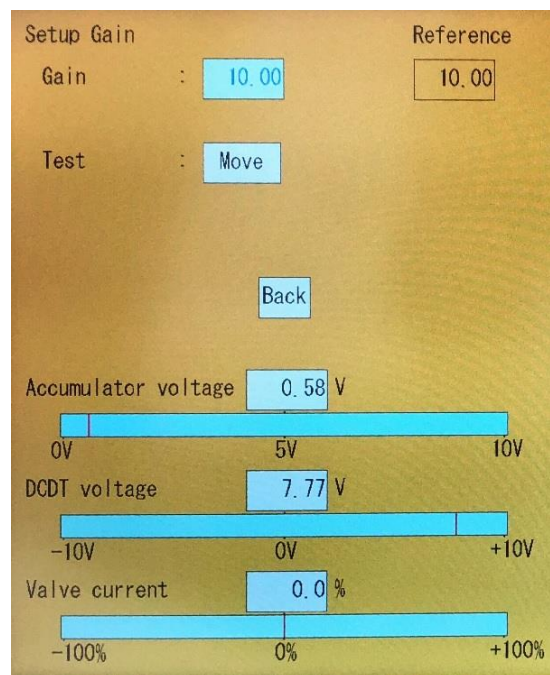

Figure 1-44 Gain setting

1.9.3.3. ACCUMULATOR MACHINE SETUP

The setup of the accumulator type blow machine is almost same as the setup procedure of the continuous blow machine. The difference is where there is a calibration of the accumulator position detector.

To shift to accumulator setup screen Move to [Accumulator] with up/down key and press [SET] or directly touch [Accumulator] on the screen. The setup screen as shown in Figure 1-46 is displayed.

* When selected continuous type machine, this parameter is not displayed.

When starting accumulator setup, it is necessary to complete setting of DCDT zero/span position, gain, and so on.

When shifting to Figure 1-46, some of the function switches on the right side of the screen will change as follows. (Red frame part)

- DEL → PURGE
- SHIFT → TOOLING

This is a function to smoothly set up the accumulator. Please check the setting of EMPTY/SPAN for details.

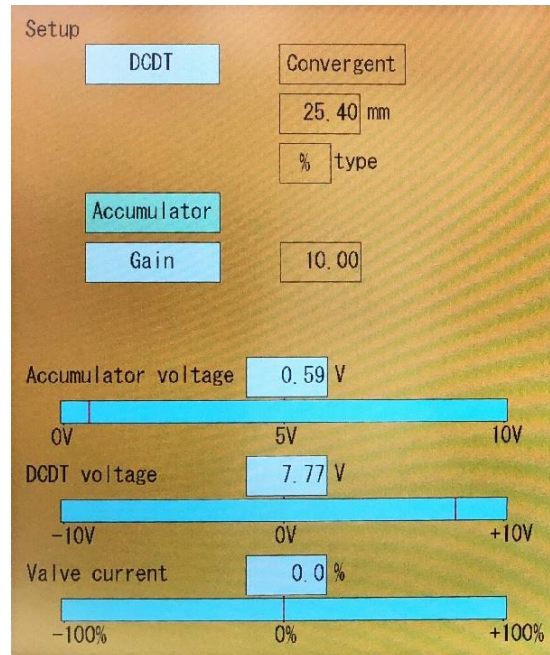

Figure 1-45 Accumulator Setup

Empty

Push the “PURGE” switch located at the lower right of the screen (Figure 1-46) to set the core to the open state (purge position) so that the resin can be easily discharged. The core opening position by PURGE is set on the F2 marker screen. (*When the core reaches the purge position, the PURGE key will return from yellow to white.If you press the PURGE key again while moving to the purge position, the PURGE key will return to white and the core will stop) Next, move the accumulator to the empty position using the host controller. When Empty is highlighted, press the [SET] key when the accumulator is in the extrusion position (empty position). The empty position is saved, and the [End of Extrusion] of the status monitoring area lights up. The highlight moves to Full (Figure 1-47).

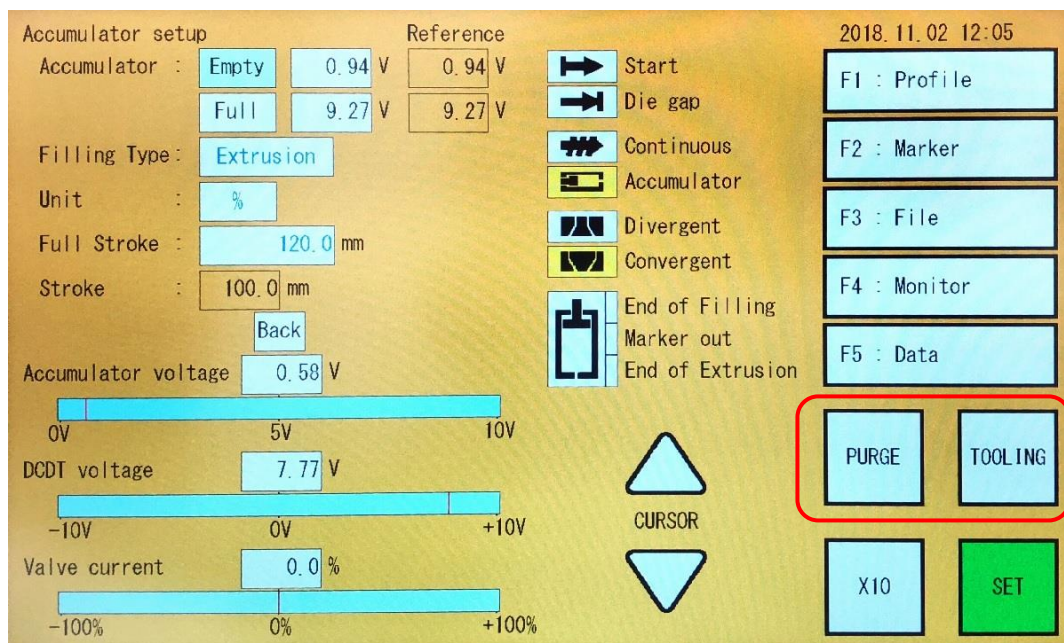

Figure 1-46 EMPTY Accumulator Set Up

Full

Next, press "TOOLONG" located at the lower right of the screen to set the core to the closed state (Tooling position). Set the core position by TOOLING on the F2 screen. (*When the core reaches the tooling position, the TOOLING key will return from yellow to white. If you press the TOOLING key again while moving to the tooling position, the TOOLING key will return to white and the core stops) Fill the accumulator using the host controller. Move the accumulator to the fully filled position (the state where the molten plastic is stored in the maximum amount). This is the [Full] position. While Full is highlighted, press the [SET] key when the accumulator is in the full fill position. The filling position is saved and [End of Filling] in the status monitoring area lights up. Highlight moves to [Filling Type].

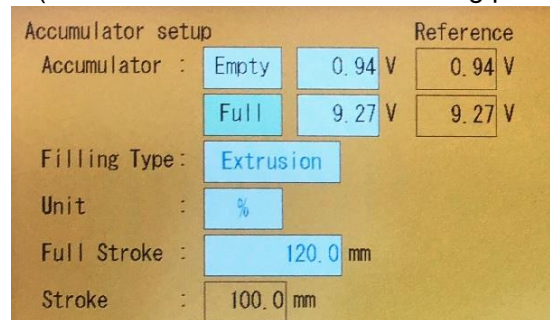

Figure 1-47 FULL Accumulator Set Up



The Empty and Full value cannot set same value, it is automatically set 0.2V space, if set same value e.g, Empty=5V and Full=5V, then automatically Empty set 4.8V.

And these two values can set only 0 to 10V. If set both 0V, value of "Full" change to 0.2V. And, if set both 10V, value of "Empty" change to 9.8V automatically.

Filling type

Next, decide Filling Type. Filling Type is the relationship between "Empty" and "Full" positions when the vertical axis (Profile Points number) on the profile data is set to "shot size" (refer to 2-4-2. F1: Profile mode) .

Extrusion

Plastic extrusion to the container mold starts at the filled Accumulator position determined by the sum of Cushion, Shot size and Delay when Filling type - Extrusion is selected. End of extrusion is the Cushion position. "Figure 1-48" End of filling position is the Shot size stroke plus Delay stroke plus the Cushion stroke

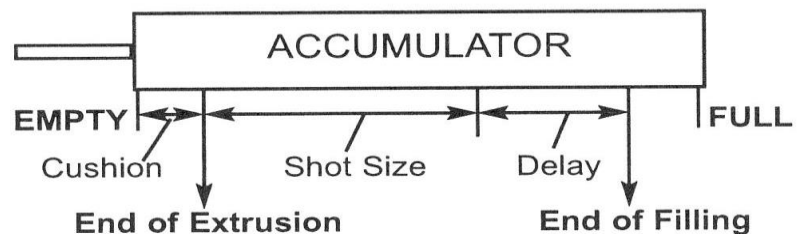

Figure 1-48 Extrusion Fixed

Filling

Plastic extrusion to the container mold starts at the Accumulator filled position (End of Filling) when FILLING FIXED is selected. The length of stroke is determined by the sum of SHOT SIZE plus DELAY. (Figure 1-49)

Select either EXTRUSION FIXED or FILLING FIXED and press SET

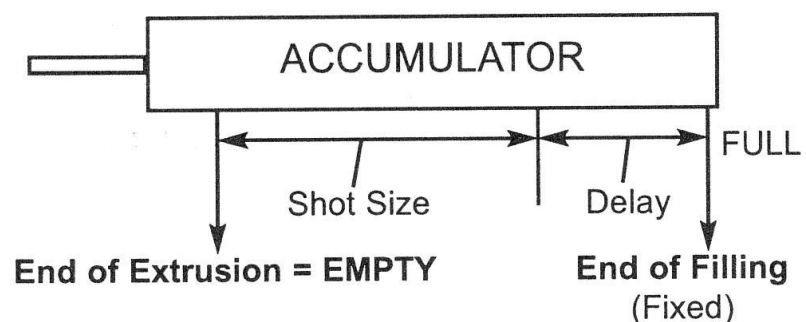

Figure 1-49 Filling Fixed

Unit

Two UNITS are available, % or MM. The Unit selected will be applied to the following parameters: on the F1 screen:

- SHOT SIZE
- DIE GAP
- DELAY
- CUSHION

Select either % or MM and press SET

Full Stroke

Use the Rotary Knob or Ten Key to indicate the length of accumulator Linearpot.

Full Stroke is set as Linearpot full stroke length. (ex, 0-10V=500 mm, Full stroke set to 500.0). The **Stroke** will automatically calculate from Empty/Full setting. Which mean 100%=Stroke(mm) showing Accumulator position reference on display.

Move the cursor to [Back] and press [SET] or directly touch [Back] on the screen to go to the setup screen.

The Accumulator blow molding machine set up process is now complete.

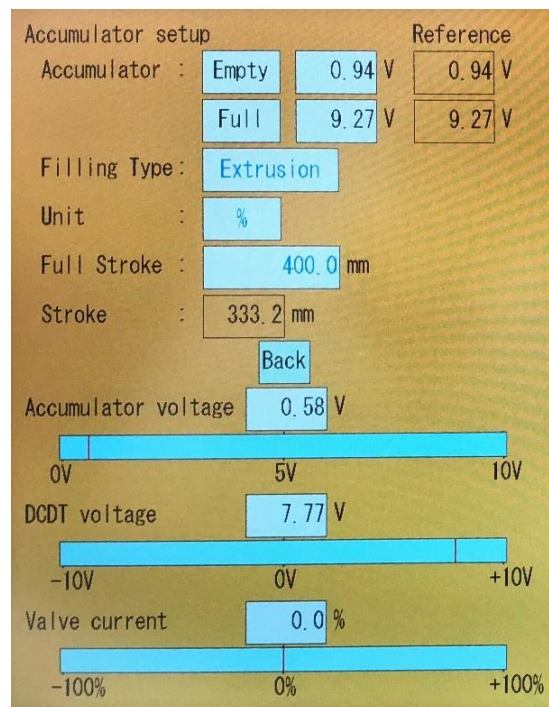

Figure 1-50 Accumulator setting (Back)

2. DigiPack III Manual, User operation

2-1. INTRODUCTION

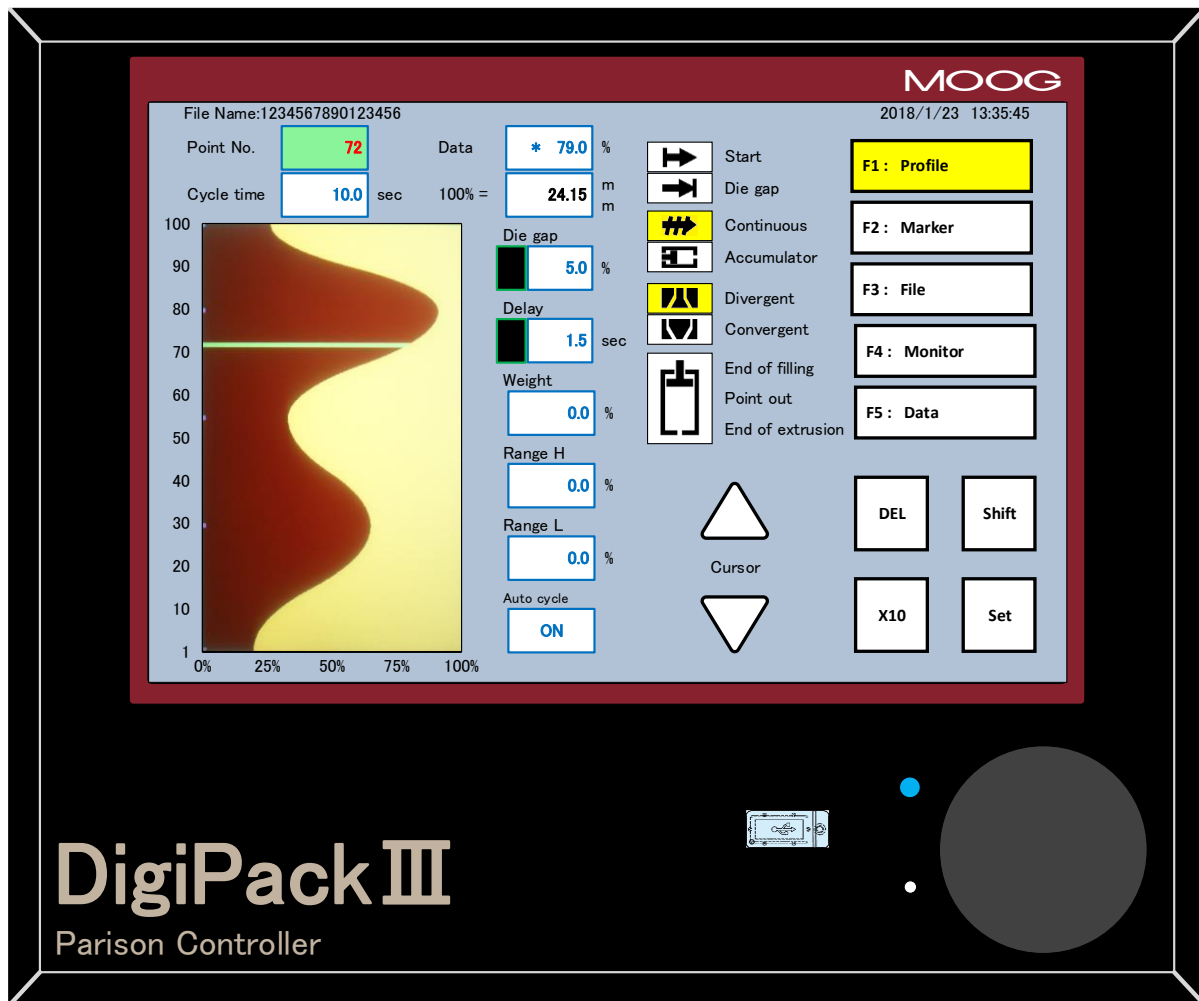

Figure 2-1 DigiPack III appearance

How do you program the DigiPack III Parison Programmer? Its job is to allow you to easily program a plastic container that will meet your customer specifications for weight and strength.

This manual will provide information about the DigiPack III's container wall thickness program setup procedure, its controls and information provided available on the front panel.

After a short learning period, you will be able to readily setup your blow molding machine to mold containers to their required specification.

2-2. PARISON CONTROL

2-2-1. HISTORY

Many different products are produced by the Blow Molding process. Any food, drug or toy store is filled with items using blow molded products. Many automobiles use blow molded windshield cleaning fluid. From a small beginning many years ago, the blow molding process has grown to a major industry.

The value of parison wall thickness control was recognized when the industry was young. Some of the early machines used two position hydraulic control of the die-mandrel gap. Others used heavy cams in strong structures to withstand the large forces involved. The first electro-hydraulic blow molding system replaced the heavy cams with light cams that were easy to modify. This was quickly followed by a readily adjustable electronic master cam used to determine the correct cam shape. Electronic interpolation then eliminated the cam. Today's parison programming systems provide reliable programming of parison wall thickness and in addition, may provide control of mold motion; screw speed; injection barrel heater temperatures, etc. or the capability to control all machine functions.

2-2-2. PARISON PROGRAMMING BENEFITS

Parison programming provides improved container quality, higher production rates and increased profits.

Control of parison wall thickness as a function of parison length results in constant container wall thickness after the parison is blown to conform to the mold.

Quality tests determine the ability of a container to withstand drop tests without bursting or leakage of its contents. Parison programming provides constant wall thickness throughout the container, insuring improved mechanical endurance at minimum weight.

Container wall thickness control reduces the container weight, eliminates the hot spots, resulting in decreased parison cooling time. The parison programmed blow molding machine's shorter cycle time results in increased production rates, combining with the decrease in material cost to ensure higher profits.

2-2-3. CONTINUOUS EXTRUSION MACHINES

A continuously rotating extruder screw pressurizes the granular plastic material, driving it through a heated tubular barrel. The resulting molten plastic is then extruded through the mandrel die gap, forming a continuous tubular parison.

As the parison never stops being formed, multiple molds are required to receive the parison in turn. One mold is in the cooling position, where the plastic cools until the container can stand alone when the mold is opened. The open mold has been moved to a position surrounding the parison, and when the parison is long enough, the mold is closed. The parison is then pressurized with air through the blow pin, causing it to expand and take the shape of the mold walls, after which the mold is moved to its cooling position. The other mold is now open and is moved to the position where it surrounds the parison and the cycle repeats.

The machine and parison program cycle is started by the knife cutting the parison. Program start Delay time may be used to properly position the programmed parison profile relative to the mold profile to insure constant wall thickness.

2-2-4. ACCUMULATOR MACHINES

Accumulator blow molding machines are normally used to make large containers. Plastic is extruded into an accumulator until the amount required (Shot Size) to make the container is available. When the mold is positioned to receive the parison the accumulator piston moves, extruding the plastic through the programmable die gap to form the parison.

A position transducer measures the accumulator piston motion and causes the parison profile to be controlled as a function of the volume of plastic extruded through the die gap. During filling, the transducer also causes the accumulator to stop filling when Shot Size is achieved.

2-2-5. PARISON PROGRAMMING BENEFITS

If the die mandrel gap is constant, the extruded parison wall thickness is constant. When the parison is expanded by air pressure, it is stretched and made thinner. The resulting container walls contain thick and thin portions depending upon the amount of parison stretching occurring during the inflation of the container.(Figure 2-2)

When this container is filled with a test fluid and dropped, it is likely to split in the heavy wall areas upon impact, due to reduced material strength resulting from uneven cooling stress. The entire container must be made thicker or more uniform to provide even cooling and improved strength.

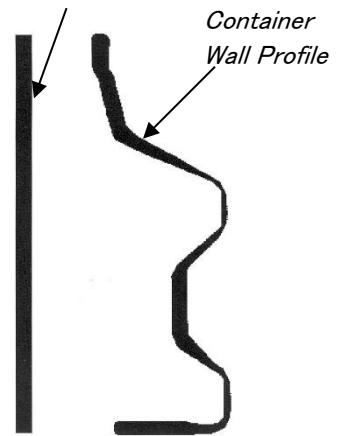

Figure 2-2 Section of an Un-programmed Parison and the Resulting Container Walls

As a result the container walls will be heavier throughout the container, require a long cooling time, material cost will increase and container production rates will decrease.

If the parison container thickness can be programmed as it is extruded by varying the die mandrel gap width, the resulting container will have constant thickness walls.(Figure 2-3)

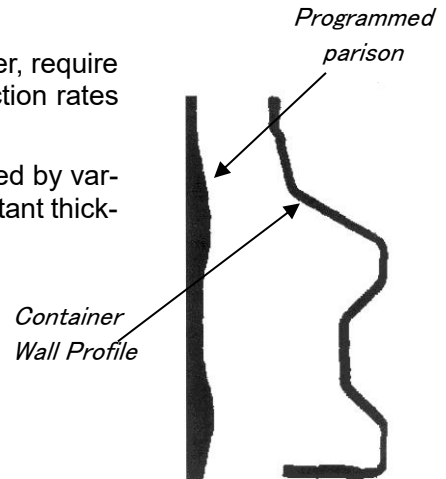

Figure 2-3 Section of a Programmed Parison and the Resulting Container Walls

This container will pass the drop test with less material as there are no heavy spots.

On average, the wall thickness will be less requiring shorter time to cool the container.

The container will have constant thickness walls.

Programmed parison wall thickness control therefore results in higher container production rates using less material per container and higher profits.

2-2-6. WITH ACCUMULATOR BLOW MOLDING MACHINES

When used with accumulator machines, the DigiPackIII controls the parison wall thickness relative to the accumulator position as the plastic is being extruded. In this case the displays (LCD) vertical axis is accumulator position and the horizontal axis is die gap opening.

The total quantity or volume of plastic extruded is proportional to the accumulator position, then the resulting parison wall thickness at any given point on the length of the container is related to the accumulator position when that point on the parison was extruded through the die gap.

A potentiometer measures the accumulator position and controls the vertical axis of the program display.

The desired shape of the parison wall profile is commanded digitally by the operator using the display. The size of the tooling opening or die gap, as measured by a die gap position transducer, is compared with the operators commanded die gap opening as set on the DigiPackIII display.

The error between the operators commanded die gap opening and the actual position causes the servovalve to control the oil flow to the actuator and reduce the difference between the commanded and the actual die gap opening (position error) to a very small value. This feedback process ensures that the actual die gap opening follows the commanded die gap opening very accurately.

The operator can also set the accumulator working stroke, Shot Size, and the desired position at the end of the accumulator push out, Cushion, the DigiPackIII also provides interfacing signals for these functions with the machines PLC, which then controls the motions of the accumulator.

2-2-7. WITH CONTINUOUS BLOW MOLDING MACHINES

When used in a continuous blow molding machine, DigiPackIII controls parison wall thickness by relative value to the time required for one machine cycle. The vertical axis of the LCD display is time and the horizontal axis is the die gap opening amount. The cycle begins, for example, when the parison cutting knife cuts the parison (actually when the start signal is input). The end of the cycle can be determined by one of the following:

- a) Fixed cycle time set by operator
- b) Automatic cycle time (cycle time is controlled by the blow molding machine) set by repeatedly measuring the time between cuts by the parison cutting knife (the time until the next start is input)
- c) Detect a fixed time cycle and activate machine functions such as closing the core (cycle time is controlled by DigiPackIII)

The desired shape of the parison wall profile is commanded digitally by the operator using the display. The size of the tooling opening or die gap, as measured by a die gap position transducer, is compared with the operators commanded position as set on the DigiPackIII display.

The error between the operator commanded position and the actual position caused the servovalve to control the oil flow to the actuator and reduce the difference between the commanded and actual die gap opening (position error) to a very small value. This feedback process ensures that the actual die gap opening follows the commanded die gap opening very accurately.

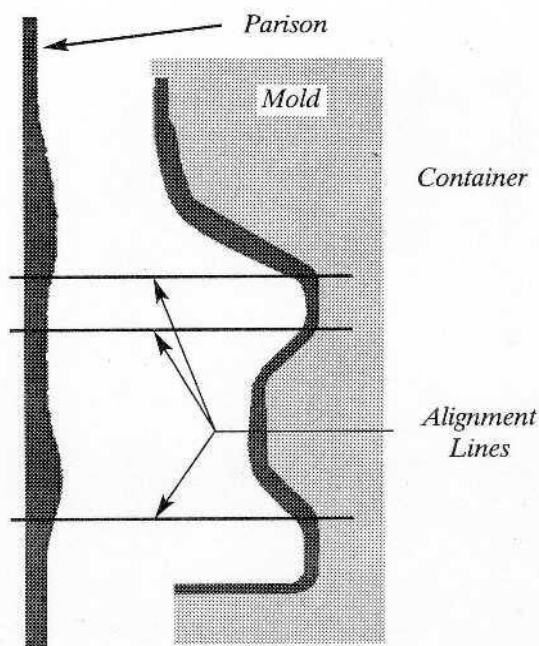

Figure 2-4 Poor Vertical Alignment Between the Parison and the Mold

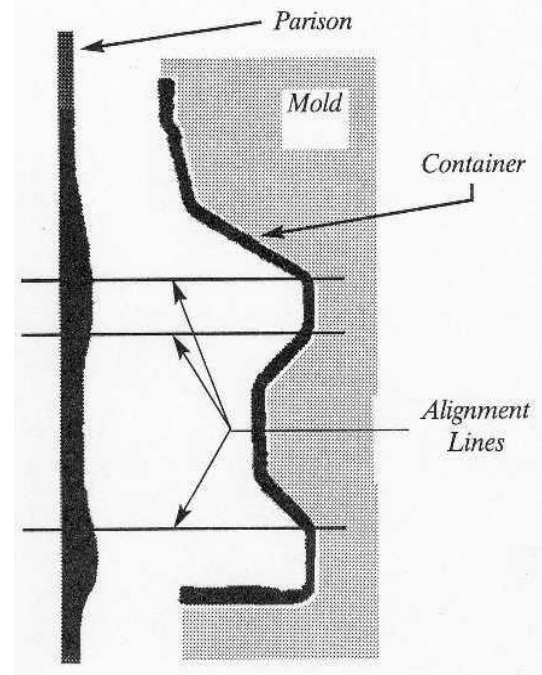

Figure 2-5 Good Vertical Alignment Between the Parison and the Mold.

2-2-8. PARISON MOLD ALIGNMENT

Alignment lines are reference lines that are displayed when cross-sectioning the positional relationship between the parison wall thickness and the product wall thickness generated after molding by blow molding.

On the alignment line shown above in Figure 2-5, the parison wall thickness is relatively thick and the core gap is large. Once the parison has been blown and molded, the wall thickness of the molded product measured on the alignment line will be nearly constant with respect to the wall thickness measured in other parts of the product.

However, if the vertical alignment relative to the mold of the parison is not accurate, the wall thickness will not be constant throughout the product and the product will have to be discarded. (Figure 2-4)

Figure 2-4 and Figure 2-5 show the parison wall thickness and the relative vertical position of the mold. When parison wall thickness is stretched by blow air pressure, the amount of drawing will change depending on the size of the inner circumference of the core. By programming the parison it is possible to produce a product with the desired constant wall thickness by aligning the thick part and the largest part of the mold inner part.

In the state shown in Figure 2-4, the parison position is higher against the position of the mold. The wall thickness profile of the parison is the same as in Figure 2-5, but there is no alignment line position for the mold. The product wall thickness on the top and bottom alignment lines is too large and the middle alignment line thickness is too small.

Lowering the position of the parison against the mold, improves the consistency of the wall thickness of the entire blow molded product and ultimately produces the correct result. However, if the parison wall thickness is further changed here, the wall thickness control will become defective again.

Please note that the horizontal alignment line is displayed as a tool showing the vertical alignment requirements of the parison and the mold. The actual movement accompanying plastic blow molding and drawing is more complicated.

2-3. MAN MACHINE INTERFACE

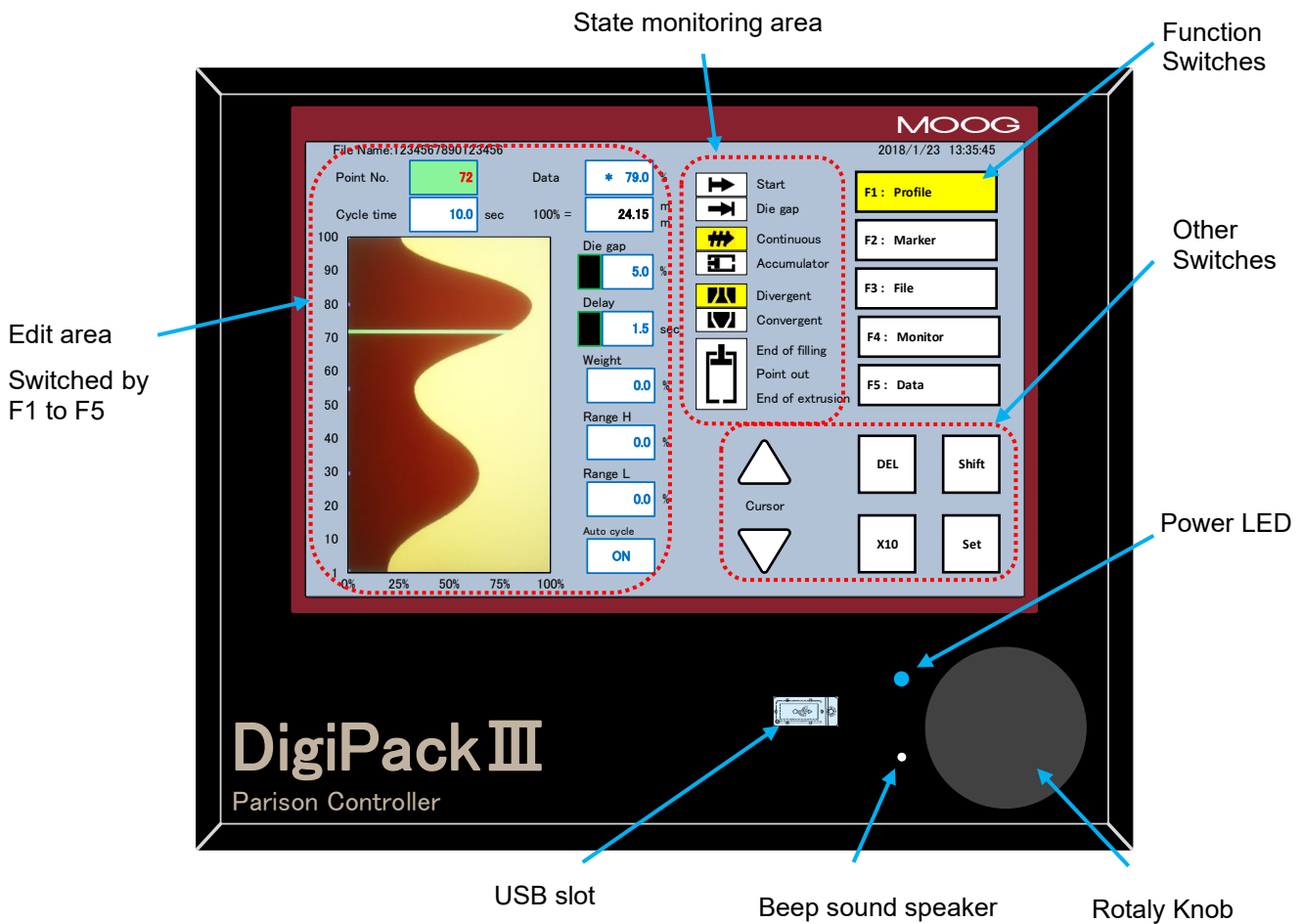

Figure 2-6 DigiPackIII Front panel

2-3-1. OPERATOR CONTROL

The operator sets and monitors the parison thickness program using the display (editing area, status monitoring area, function switch, other switches) and rotary knobs on the DigiPackIII front panel shown in Figure 2-6.

All functions normally required for parison and machine programming can be used on the front panel.

2-3-2. INPUT FUNCTION

Rotary knob (numerical input) :

It is used to input values of various functions, turning clockwise increases the value of the function, turning counterclockwise decreases the value. When the "X10" key on the screen is active (inverted to yellow), the sensitivity when the input knob is rotated is multiplied by 10.

Setting value by ten key (10 key) :

In addition to the method by pressing [SET] after increasing / decreasing the value by the rotary knob, you can input with the numeric keypad displayed on the screen to set the value. If you select a parameter and rotate the rotary knob, the selected parameter value will be enlarged as shown in Figure 2-7. This value increases or decreases following the rotation of the rotary knob. Also, if you touch the selected parameter again, the numeric keypad will be displayed. In this case, the numeric keypad becomes active from the beginning as shown in Figure 2-8.

If you press "ESC" or touch anything other than the numeric keypad area, the screen returns to Figure 2-6 without changing the value. Press the "SET" key to update the value and return to Figure 2-6.

Selected value zoomed

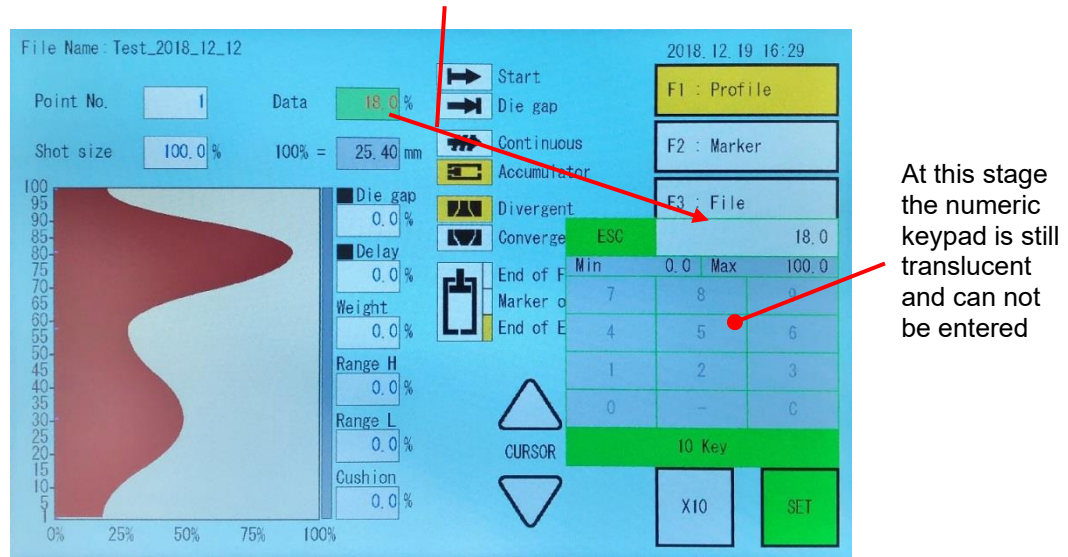

Figure 2-7 Ten key on the screen (1)

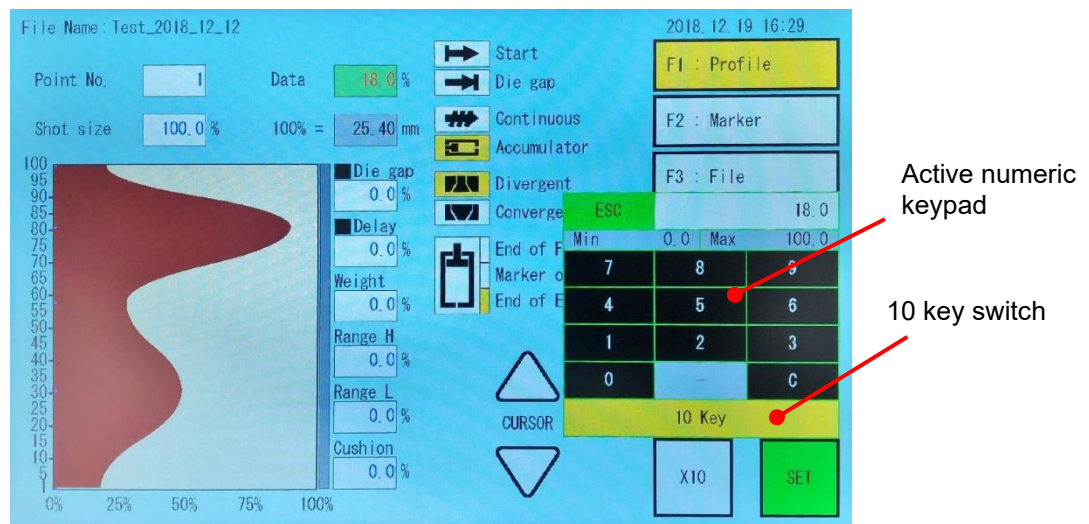

Figure 2-8 Ten key on the screen (2)

If you press the "10 Keys" switch from the state shown in Figure 2-7, or touch the selected parameter again from the state of Figure 2-6, the numeric keypad becomes active as shown in Figure 2-8. You can enter a value with the numeric keypad. When you use the numeric keypad, the original value is cleared. For example, pressing "1" changes the value to 1. After that, when you use the rotary knob, the value increases or decreases based on that value.

If you press "ESC" or touch anything other than the numeric keypad area, the screen will return to Figure 2-6 without changing the value. Press the "SET" key to update the value and return to Figure 2-6. Also, when the numeric keypad is active, pressing the [C] key clears the input contents and can re-enter. I will explain the rules for entering 10 keys on the next page.

1) Numeric keys

(1) In the case of a parameter having a decimal point unit: The input value is shifted from the right and input.

Example) 0.0 → "1 input" → 0.1 → "2 input" → 1.2 → "3 input" → 12.3

(2) In the case of integer parameter: The input value is input shifted from the right.

Example) 0 → "1 input" → 1 → "2 input" → 12 → "3 input" → 123

2) minus key (-)

(1) When the parameter input range is minus: +/- toggles. The key is always valid.

Example) -16.5 → "- input" → 16.5 → "- input" → -16.5

(2) When the parameter input range does not reach minus: minus key is invalid (no minus display)

Example) 3.2 → "Input" → 3.2 → "- input" → 3.2

3) ESC key

Returns the input value before change and returns to the normal screen.

4) C key

Clear to 0 which is currently input.

5) SET key

It reflects the input value and returns to the normal screen.

6) MAX / MIN indication

Displayable range of the specified parameter is displayed.

[X10] :

Increase the sensitivity of the rotaly knob by 10 times. The color of the switch changes from white to yellow while active. Press again to deactivate and switch to white.

[SET] :

If you press the [SET] key while it is shown in green, the setting item value is confirmed. When the value is changed with the rotaly knob or the numeric keypad, the color of the [SET] key changes from white to green. At that time, press the [SET] key to confirm the set value. [ESC] or cancels the change with touch other than the numeric keypad, without pressing [SET], the selection parameters are changed back to original value and the [SET] switch returns to white.

Cursor(△▽):

Move the selection parameter on the LCD in the direction indicated by triangle.

[DEL] :

In the [F1] profile edit screen, invalidate the set thickness point. When you tap [DEL] on the set point, the [DEL] switch turns green. If you tap again the [DEL] switch, [DEL] is executed to invalidate the thickness point and it becomes interpolation data between specified points before and after.

* When setting the accumulator, this switch changes to the [PURGE] function.

[SHIFT] :

While this switch is pressed and "SHIFT" is in the active state (switch is yellow), the screen called by the F1 to F5 switches becomes the setting screen. If you press this switch again or select one of the setting screens of F1 to F5, "SHIFT" becomes inactive (switch is white). * Please refer to 1-2-6 for the protection of setting screen transition

* When setting the accumulator, this switch changes to the [TOOLING] function.

2-3-3. FUNCTIONS

It is used to select the function screen displayed in the editing area shown in Figure 2-6. The contents of the function are as follows.

F1 Profile	Controls the parison wall profile and other related functions (When start up the controller, first move to this screen)
F2 Marker	Set program point marker. Slope setting for die gap and start slope. Time setting of internal clock. PURGE / TOOLING target position setting
F3 File	Allows storage and retrieval of 100 container wall thickness programs and related functions
F4 Monitor	Display status of digital signal and current value of servo valve current and die gap position. Manual operation is also done on this screen.
F5 Data	Displays the profile point and related function data
SHIFT→F1	Set Up Mode – Provides die gap tooling and other machine related set up functions
SHIFT→F2	Analog monitor assignment to monitor channels.
SHIFT→F3	Delete and Backup/Restore the storage data. (Backup/Restore for data in USB)
SHIFT→F4	Machine primary setting setup
SHIFT→F5	Communication parameter setting RS422 and Ethernet. And Inter clock time setting

2-3-4. STATE MONITORING AREA

In the status monitoring area shown in Figure 2-6, it is used to indicate the state of the function as shown below.

Start	Lights when the cycle Start signal is received
Die Gap	Lights when the Die Gap signal is received and “DIE GAP” on the LCD is back lit
Continuous	Lit when the “Continuous Extrusion” machine type is selected
Accumulator	Lit when “Accumulator” machine type is selected
Divergent	Lit when “Divergent” die gap tooling is selected
Convergent	Lit when “Convergent” die gap tooling is selected
End of filling	Lights when the accumulator completes its charging stroke
Point Out	Lights when each Marker point is reached
End of extrusion	Lights when the accumulator completes its empty stroke

STATUS INDICATORS

There are two status indicators on the [F1] profile page (Figure 2-9). The status can be checked as follows depending on the status of the indicator.

Running or Ready	Die gap and Delay are not highlighted
Die gap	Die gap is highlighted
Delay	Delay is highlighted

Status Condition

Running or Ready:

- 1) When the mode is changed from MANUAL to AUTO
- 2) When the power is turned on or the DigPackIII is reboot
- 3) When the STOP signal is input
- 4) End of movement of the Delay to until Diegap signal ON.

Die gap:

From DieGap signal and while core on the Die gap position

Delay:

From Start signal and while Delay running

Status indicator

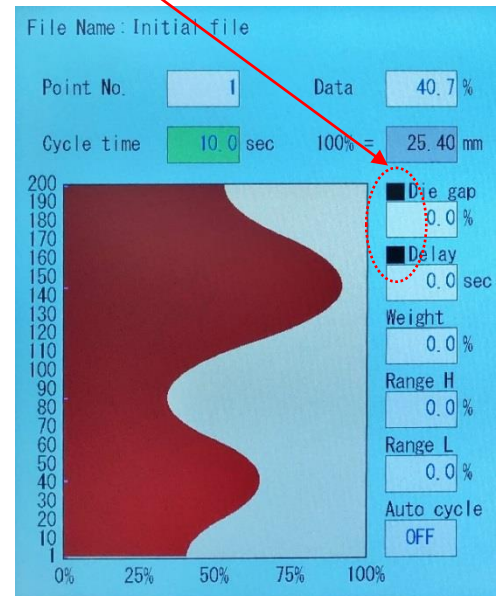

Figure 2-9 Status indicator

2-3-5. EDIT AREA

In the edit area shown in Figure 2-6, the detail screen when the specific function key [F1-F5] selected is displayed.

Selection of the individual Function Items is done by the Cursor or touch directly. In Figure 2-9, the value of the Item **Cycle time**, 10.0 sec, is highlighted and therefore **Cycle time** is selected. Turning the **Rotary Knob** will increase (CW) or decrease (CCW) the **Cycle time** value. To make this **Cycle time** change permanent, **SET** must be pressed. If do not press SET and press ESC or move the cursor here, the value of **Cycle time** will be restored. * For details of value input method, please refer to section 2-3-2.

Selection of other Function Items is done by repeatedly pressing the Up or Down **Cursor** until the desired Item is reached or touch the item directly. In this manner, all of the individual Function Items may be selected. The value of any Function Item will not be changed when moving between Function Items unless **SET** is pressed.

This input procedure applies to all Function screens.

2-4. SCREENS OF EDIT AREA

Explanation here is given (profile point = 100 points).

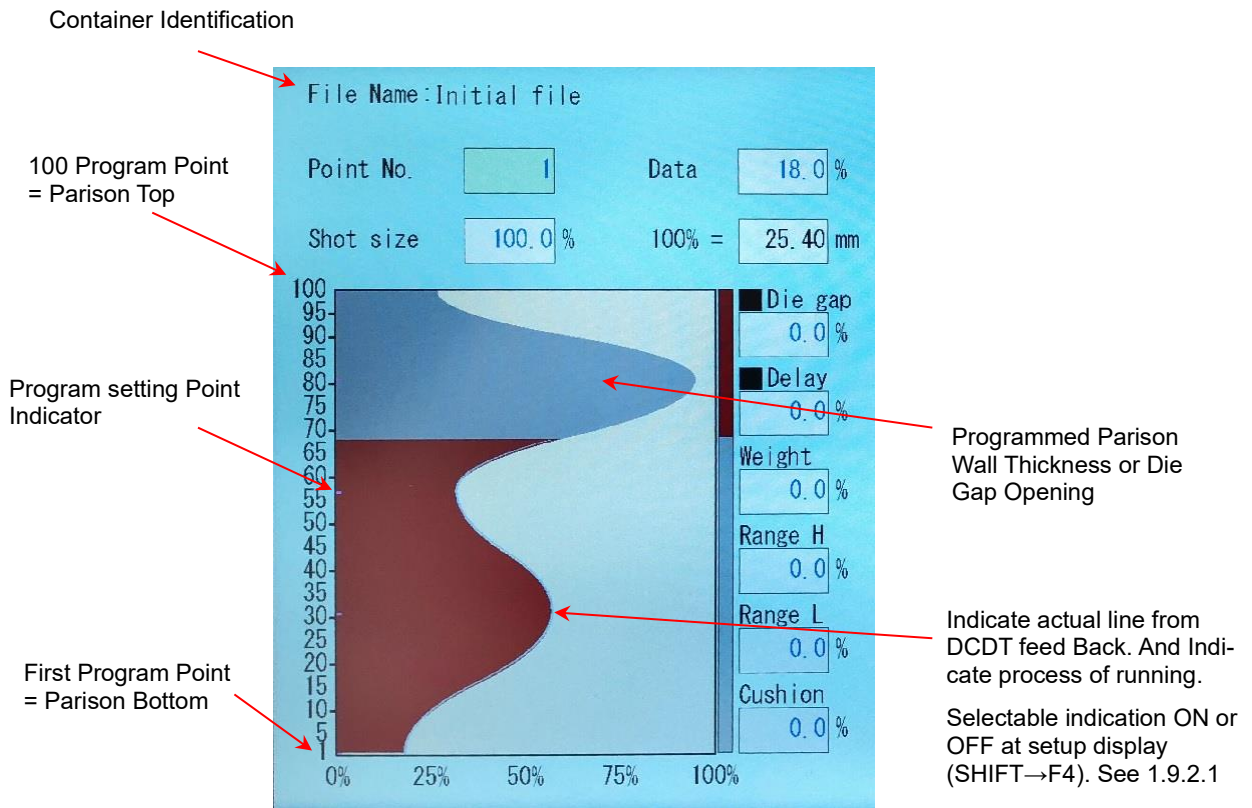

Figure 2-10 F1: Profile mode Screen

2-4-1. EDITING METHOD

The **Cursor** key (up/down) is used to move the cursor to each displayed **parameter item**. And also select items by touching directly. The **Cursor** will indicate its location by light green on LCD display. If the cursor put on to Point No. the cursor in Profile graph will move by rotating the **Rotaly Knob** (Clockwise to up, Counterclockwise to down; **X10** key makes the **Rotaly Knob** faster) to obtain the desired value, then confirm the value by pressing the **SET** key. And, If the cursor put on to Data, the cursor in Profile graph will move by rotating the **Rotaly Knob** (Clockwise to increase, Counterclockwise to decrease; **X10** key makes the **Rotaly Knob** faster) to obtain the desired value, then confirm the value by pressing the **SET** key.



If change the item value but press ESC without confirmation with the SET key, that value returns. (Some parameters are excluded)

If set values are modified, changes take effect during the next machine cycle.

2-4-2. F1: Profile Mode

Mode obtained by pressing the **F1** Key.

Display condition:

Normally displayed when manufacturing containers.

Profile Mode Function Items

Please refer to Figure 2-11 and description below for further definition information.

Die Gap Opening Profile

The profile uses 10 to 200 separate points to define the desired parison wall thickness profile. The horizontal axis of the LCD display is the programmed tooling die gap or parison wall thickness. The points along the vertical axis of the LCD display are Shot Size, either cycle time or accumulator stroke.

Linear or Spline interpolation can be set at machine setup display (SHIFT→F4) is used to define the profile between the operator set points. *Figure 2-11 showing Spline type.

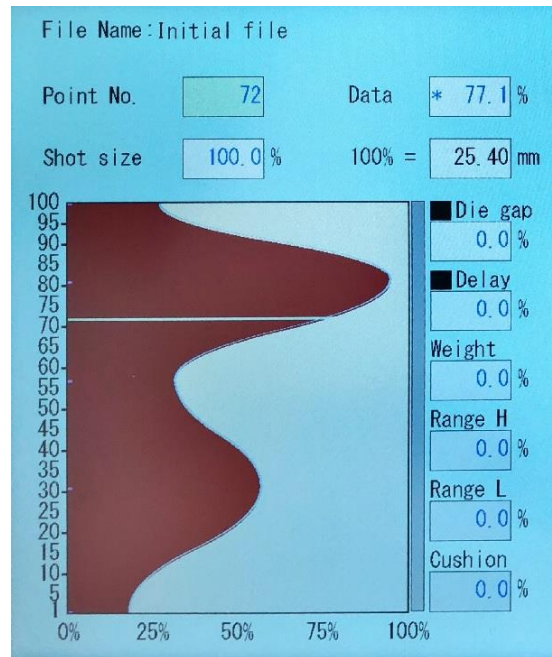

Figure 2-11 Profile Mode Screen

Each profile point may be set to a value between 0% to 100% of the maximum tooling die gap opening by rotating the **Rotaly Knob** and pressing **SET**. (For definition of 0-100% see 1.9.3.1)

As shown in Figure 2-11 Profile Mode Screen, the active profile point on the display is indicated by a inverse video bar. Its value is shown on the upper right hand corner of the LCD display as "**Data %**"(77.1% on Figure 2-11). Points displayed as "*" are interpolated values. If the value not displayed "*" its settled program point, you can also see setting point with purple color line mark on profile left side as shown Figure 2-11.

If "-" is being displayed as a point value of left side of profile, that value has been set using **F2: Marker Mode**.



To cancel entered profile points, turn the Rotaly Knob counterclockwise until the display in the upper right hand corner of the LCD display indicates "**Data: ---.-**" and press the **SET** Key or move to the point where you want to cancel the green bar and delete the setting with the [DEL] key. After deletion, it will be changed to interpolation value.

The scale of the profile display will automatically change between 25%, 50%, 75% and 100% as required.

The following Function Items are found in the area of the LCD display around the parison profile.

Point No.

If the cursor placed on this value, the profile bar in the graph can be moved up and down by turn the **Rotaly Knob**, CW to move up and CCW to move down. Once decided cursor point on profile graph press **SET** key, and cursor move to **Data** value.

Data

If the cursor placed on this value, the profile thickness can be adjust increase and decrease by turn the **Rotaly Knob**, CW to increase and CCW to decrease. Once decided profile thickness on this profile point, press **SET** key, and cursor move back to **Point No.** value.

* The profile adjustment affected to next start cycle.

Shot Size

Shot Size sets the quantity of plastic used during one machine cycle to produce a container. The setting type is different depending on the accumulator or continuous machine type.

Accumulator Machines – the amount of plastic extruded by the accumulator or accumulator stroke. **Shot Size** is shown as a percentage (or mm) of the accumulator stroke and its value may only be set between 1% and 100%.

Continuous Extrusion Machines – the length of time for one machine cycle in seconds. **Cycle Time** may only be set between 0.1 and 999.9 seconds. This time is started by machine event, such as the motion of the knife cutting the parison.

An additional feature is **Auto Shot** which automatically sets **Shot Size** to be equal to the time interval between sequential knife cuts. If **Auto Shot** is ON then **Shot Size** automatically update each cycle interval, and **Shot Size** is no effect on the cycle time.

Die Gap

This parameter is the core gap target position when the die gap digital signal (TB-2-2) is input. Set the core die gap opening amount on the cycle between the end of the program profile (point 200) and the start of the next cycle. The setting range can be set between 0 and 100% with respect to the maximum value of the core die gap opening amount. Also, if this parameter is changed while the [Die gap] status ([Die gap] status indicator is green), the core gap changes at the speed of [Die gap slope] setting when pressing the [SET] key Move to a setting position.

In general, [die gap] is used to control the thickness of the parison in a continuous blow molding machine (for example, resin cutting etc.), in the accumulator molding machine to close the core gap and prevent resin drooping during filling.

Delay

Delay delays the start of the programmed profile after the machine cycle is started. During this **Delay** the tooling die gap is maintained at the gap programmed by profile point 1. **Delay** may be set from 0% to 999.9% of the **Shot Size in ACC mode**. If Continuous Extrusion mode, **Delay** may be set from 0sec to 999.9sec

Delay is often used to synchronize the position of the initial programmed portion (bottom) of the parison with the bottom of the container mold.

Cushion

Cushion applies to Accumulator Machines and when filling type selected to Extrusion only.

Cushion is the point where the accumulator stopped with pushed out. **Cushion** is often set to leave a small amount of material in the accumulator at the end of the push out to insure that the accumulator does not bottom out before all of the plastic required for programmed portion of the parison is extruded.

As the total accumulator stroke has been made equal to a **Shot Size** setting of 100%, the total of the equation

$$\begin{aligned} & \text{Shot Size} + \text{Shot Size} \times \text{Delay} \\ & + \text{Shot Size} \times \text{Cushion} \end{aligned}$$

must be equal to or less than 100% of the actual maximum accumulator stroke.

Auto Cycle

Applicable only with continuous extrusion machines. It is not displayed on the accumulator type machine. This parameter automatically sets [cycle time] to a value equal to the time interval between successive start signals (TB-2-1). When [Auto cycle] is set to ON, [Cycle time] is automatically updated every interval of each cycle.

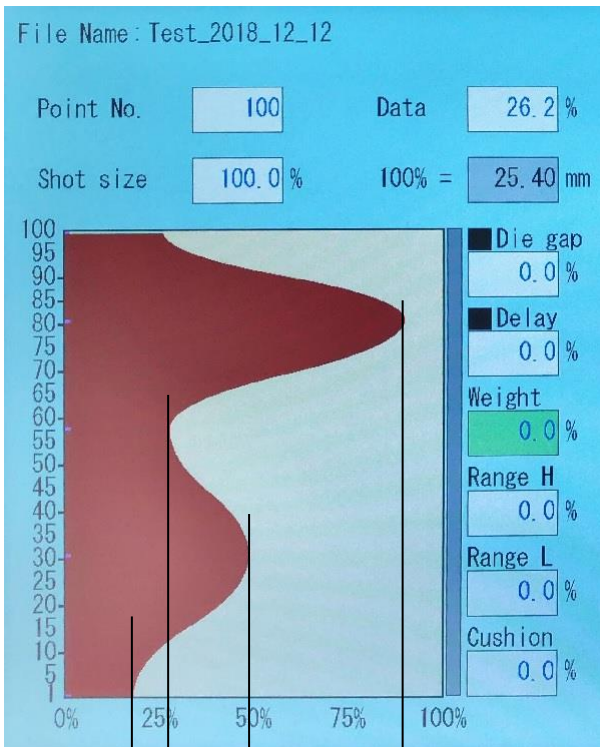

Figure 2-12 0% Weight Change

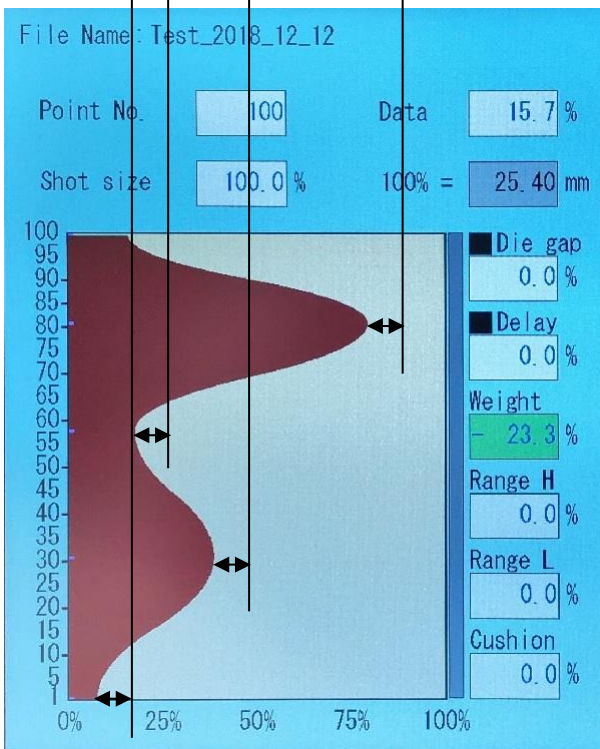

Figure 2-13 (-)23.3% Weight Change

Weight

Weight is a constant value added to each profile point and when varied, has the effect of changing container weight roughly in proportion to the amount of weight change.

As used on the DigiPackIII, **Weight** produces a change proportional to the average thickness of the parison. For a given **Weight** change, the amount of change at each program point is related to the initial value of that point. The effect is to provide a container weight change with a minimal effect on the container wall thickness distribution.

Weight is expressed as a percentage of the thickest point on the profile. **Weight** can vary from minus 100% to plus 100%. Weight reduction can occur until the value of one of the 200 profile points reaches zero.

* If the profile over 100%, **Weight** still can be increase continuously up to 100%, however actual profile command is 100% maximum.

Use the **Rotary Knob** and **Set** to change the **Weight** setting. The percentage **Weight** change will remain displayed after being **Set**. When the **Rotary Knob** is turned again the new **Weight** entry will start at zero using the current display as reference. If the **Rotary Knob** is accidentally moved and the displayed **Weight** value changed, it will revert to its former value if **SET** is not pressed and the **Cursor** used.

When you start to generate the profile for a container for the first time, the **Weight** displayed will equal zero. After a **Weight** change has occurred, the **Weight** displayed will indicate the percentage **Weight** change.

Figure 2-13 shows the effect of a **Weight** reduction of -23.3% from the **Weight** value of 0% in Figure 2-12. To make the change easier to visualize, reference lines drawn between the figures starting at four different parison wall thickness program points have been included. The **Weight** change will be same from minimum to maximum parison wall thickness program point.

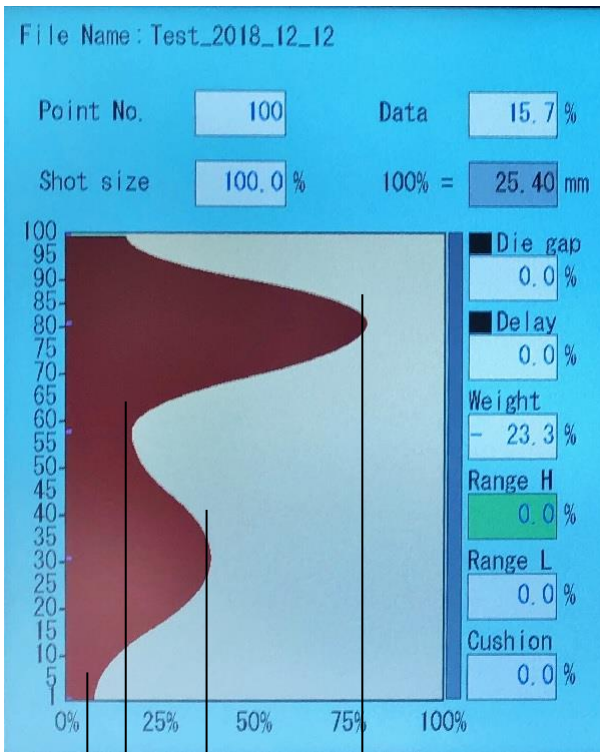

Figure 2-14 0% Range H

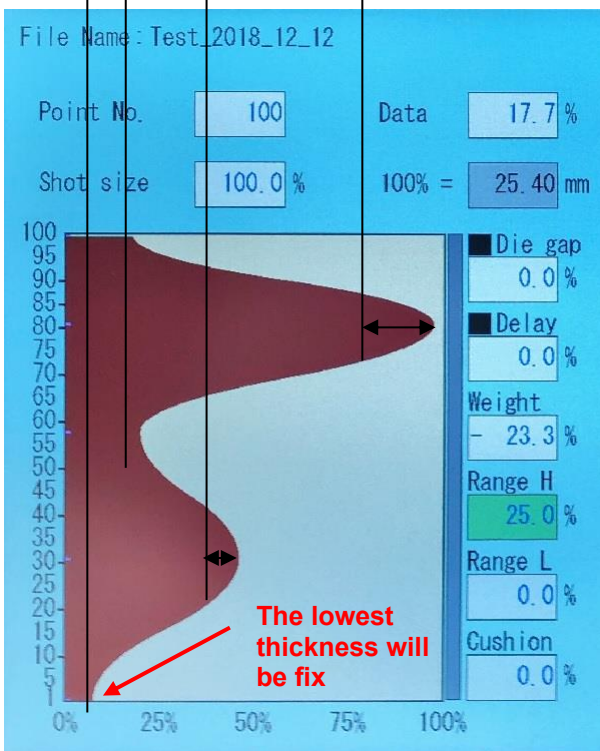

Figure 2-15 (+)25.0% Range H Change

Range H

Range H changes the value of all profile points by a percentage of the difference between the thickness and thinnest points. The value of the thinnest profile point remains constant during a **Range H** change. **Range H** can vary between -100% and non limit + side (3276.7%).

* If the profile over 100%, **Range H** still can be increase continuously, however actual profile command is 100% maximum.

Use the **Rotaly Knob** and **SET** to change the **Range H** setting. The percentage **Range H** change will remain displayed after being **Set**. When the **Rotaly Knob** is turned again the new **Range H** entry will start at zero using the current display as a reference. If the **Rotaly Knob** is accidentally moved and the displayed **Range H** value changed, it will revert to its former value if **SET** is not pressed and the **Cursor** used.

Range H has the effect of allowing container weight changes while retaining the containers minimum wall thickness distribution pattern.

Figure 2-15 shows the effect of a **Range H** increase of +25.0% from the **Range H** value of 0% in Figure 2-14. To make the change easier to visualize, reference lines drawn between the figures starting at four different parison wall thickness program points have been included.

Range H will use the thinnest parison wall thickness program point as a reference and will not change its thickness. The **Range H** change will be largest at the maximum parison wall thickness point, and proportionately less at the intermediate parison wall thickness points.

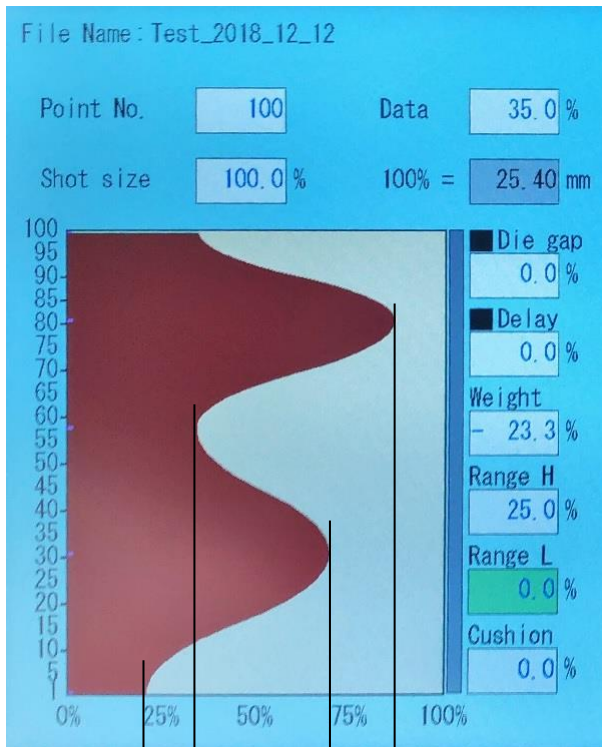

Figure 2-16 0% Range L

Range L

Range L changes the value of all profile points by a percentage of the difference between the thickest and thinnest points. The value of the thickest profile point remains constant during a **Range L** change. **Range L** can vary between -3276.7% and +100%. **Range L** may be changed until the thinnest profile point reaches zero. Use the **Rotary Knob** and **SET** to change the **Range L** setting. The percentage **Range L** change will remain displayed after being **Set**. When the **Entry Knob** is turned again the new **Range L** entry will start at zero using the current display as a reference. If the **Rotary Knob** is accidentally moved and the displayed **Range L** value changed, it will revert to its former value if **SET** is not pressed and the **Cursor** used.

Range L has the effect of allowing container weight changes while retaining the containers maximum wall thickness distribution pattern.

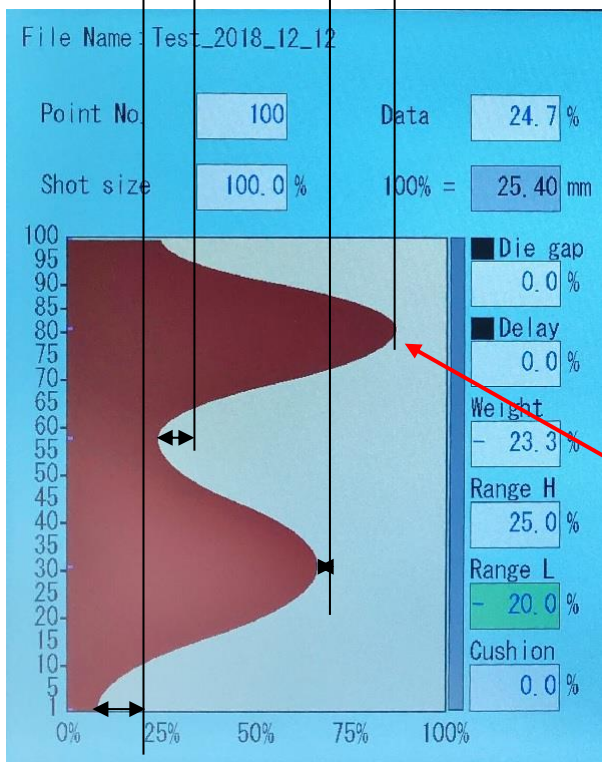

Figure 2-17 (-)20.0% Range L

Figure 2-17 shows the effect of a **Range L** decrease of -20.0% from the **Range L** value of 0% in Figure 2-16. To make the change easier to visualize, reference lines drawn between the figures starting at four different parison wall thickness program points have been included.

Range L will use the thickness parison wall thickness program point as a reference and will not change its thickness. The **Range L** change will be largest at the minimum parison wall thickness point, and proportionately less at the intermediate parison wall thickness points.

The highest thickness will be fix

2-4-3. F2: Marker Mode

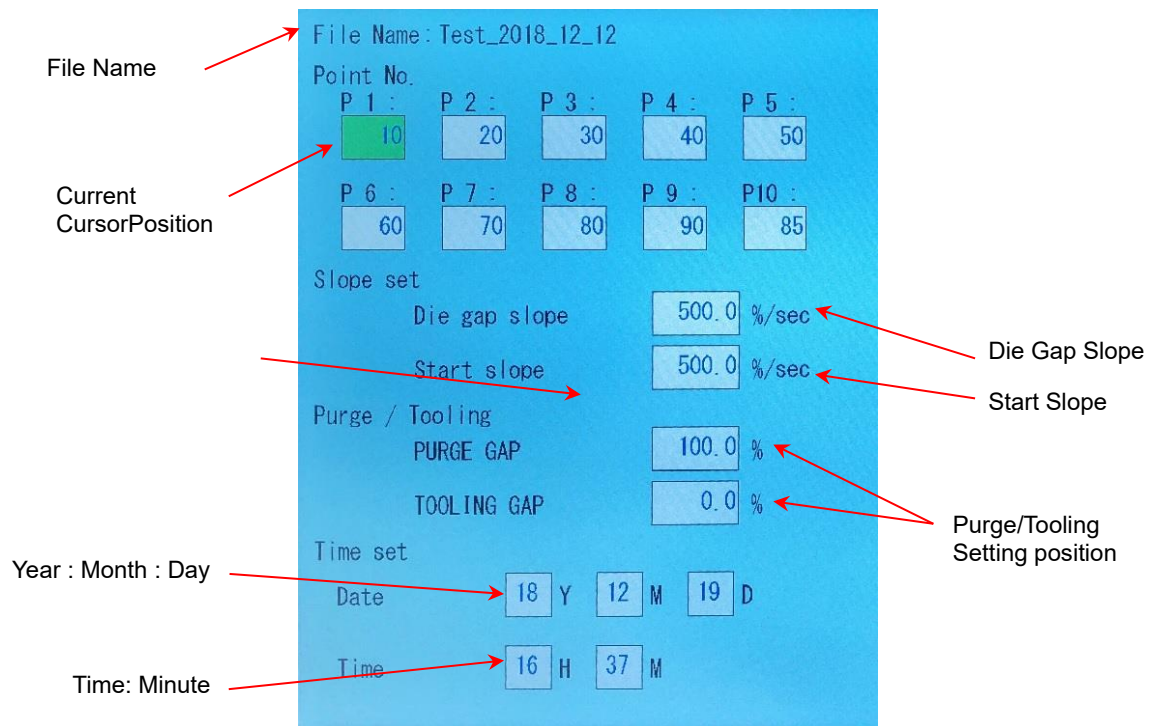

Figure 2-18 Marker Mode Screen

Mode is obtained by pushing the **F2** Key.

Display

Available when manufacturing containers.

Point No.

Set the profile point marker up to 10 points on the profile. To set these conditions, move from point to point using the **Cursor** Key and set point number with the Rotary Knob or Ten key and press **SET** Key to confirm. The value can be set from 0 to 200, and If set point number to "0", this mean not set this marker point.

Use

May be used to provide a pulse output (200msec)(TB-2-20) occurring at a selectable point in the Digi-PackIII cycle to control and/or synchronize machine functions or for other uses.

Die gap slope

The slope or velocity of the motion to the "Die Gap" setting position, when the Die Gap signal is given. Setting range is 0.1 to 999.9%/sec. Please refer to **Figure 2-19** for the timing.

Start slope

The slope or velocity of motion to Point 1 position, when the Start Slope signal is given. Setting range is 0.1 to 999.9%/sec. Valid only when the "Filling" status is indicated. When the start position is reached by the start slope, the start slope end signal (TB-2-22) is output. Please refer to **Figure 2-19** for the timing.

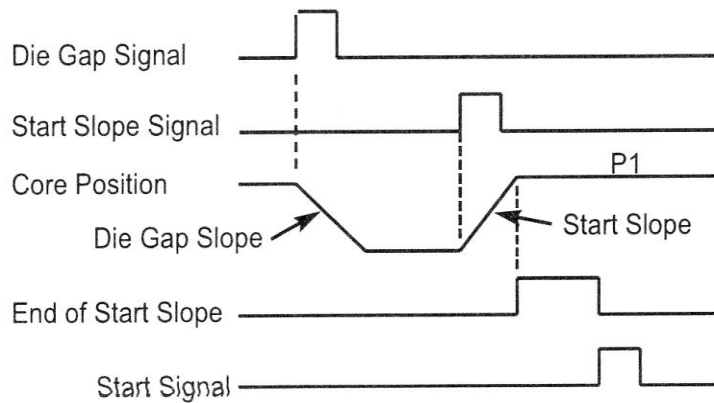

Figure 2-19 Slope Timing

PURGE GAP

With this parameter, set the core movement target position (PURGE opening) by the [PURGE] switch located at the following two places. Setting range 0 to 100% (Initial value 100%) (For definition of 0 to 100% see 1.9.3.1)

- F4: Monitor screen: PURGE switch can be pushed in the manual mode.
- Accumulator setting screen: The PURGE key is displayed when accumulator initial setting page is indicating. (DEL key changes to PURGE key)

TOOLING GAP

With this parameter, set the core movement target position (TOOLING closing) by the [TOOLING] switch located in the following two places. Setting range 0 to 100% (Initial value 0%) (For definition of 0 to 100% see 1.9.3.1)

- F4: Monitor screen: TOOLING switch can be pushed in the manual mode..
- Accumulator setting screen: The TOOLING key is displayed when accumulator initial setting page is indicating.. (SHIFT key changes to TOOLING key)

* PURGE / TOOLING is the core forced opening and closing function. This function is effective when replacing resin or when performing initial setting (zero-span) of the accumulator.

* The speed of the core moved by the PURGE / TOOLING switch is the speed set by "Die gap slope".

* Refer to Section 1.9.3.3 Accumulator setup for the purge / tooling function during accumulator setting.

Time set

A time setup of an internal timer is performed.

When there is no time correctly by an initial state or no long-term turning on electricity, time is set up on this screen.

Date

A date is inputted.

Time

Time is set up.

SET

After inputting a date and time, a timer is set up by SET and a count is started.

2-4-4. F3: File Mode

Mode is obtained by pressing the **F3** Key.

Display

Available when manufacturing containers.

Function

This mode combines the profile, marker data and setup files and stores them in a Flash RAM or USB Memory for future use. To Flash RAM 100 files can be stored, and SD card can be saved data depend on the size of USB Memory. The data stored with identifying name of up to 32 characters, date and time.

Commands

When F3: File Mode is selected a choice Load, Load USB, Save or Save USB, is displayed (Figure 2-20). Load, Load USB, Save or Save USB can be selected, using the Cursor and Set or directly touch the applicable item.

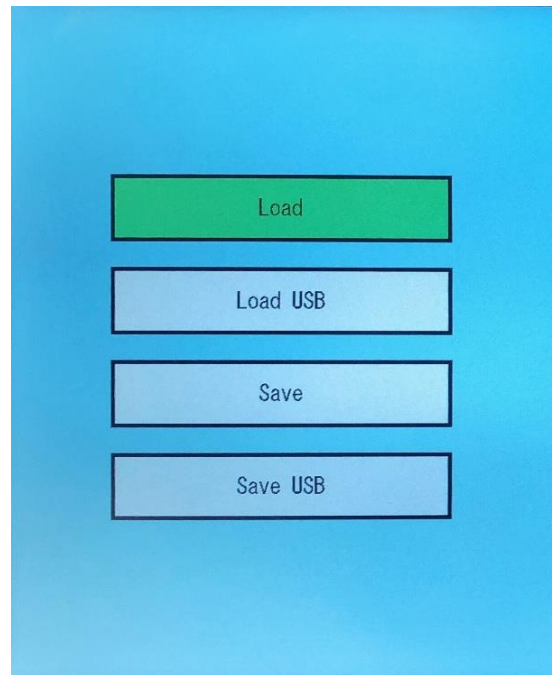

Figure 2-20 File Mode Selection Screen



For USB memory writing or reading, USB memory must be inserted in the slot. If it is not inserted, the following message will be displayed and file management can not be continued.

“USB is not insert or format is not correct”

※ The maximum usable USB size is 32GB, the data format format is FAT32.

Please note that if you select [Load] or [Load USB], the current product data will be automatically over-written. Please save the current product data, before load the data.

Save or Save USB

Save or Save USB combines the profile data, function item data and point markers in one file and stores this file in the Flash RAM or USB Memory.

Use the **Up/Down cursor** to select **Save or Save USB** and press the **SET** Key or directly touch them. (Figure 2-20)

The prompt **‘Please edit file name Yes/No’** is displayed. (Figure 1-21)

If you select **“YES”**: then go to Page 63.

If you select **“NO”** then go to Page 62.

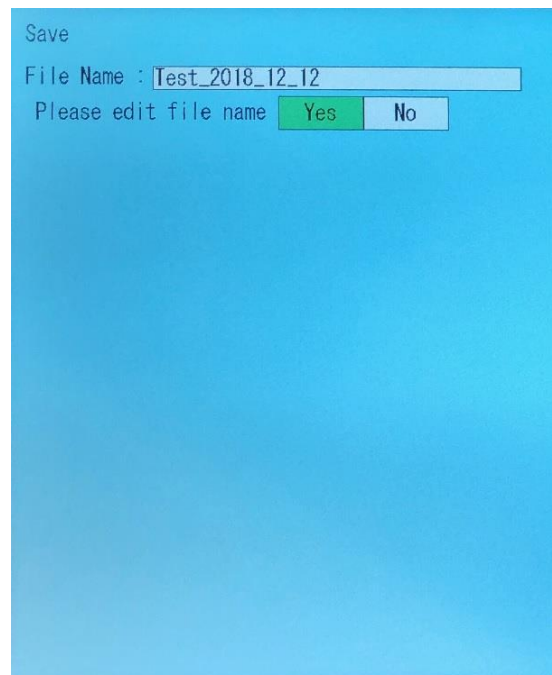

Figure 2-21 Select SAVE

“Please edit file name Yes/No”

If you select “No” then follow the instructions below..

The LCD display (Figure 2-22,Figure 2-23,Figure 2-24) shows the description of the file data, press SET at “Next” to see each display one by one.

To save the file, move cursor to “Save” with **Rotaly Knob** and press **SET** Key or directly touch “Save”.

If you select “Save”, the DigiPackIII saves the data in the Flash RAM (or to the USB Memory if you selected Save USB) and displays the save data in the **Profile** mode. (**F1: Profile**).

If you select “Quit” the first screen of the **F3 File** mode is displayed and no data is saved.



The data will automatically be saved in the same “FILE Number” file shown in the LCD display even if data is already stored there. In this case, the previously stored data will be lost.

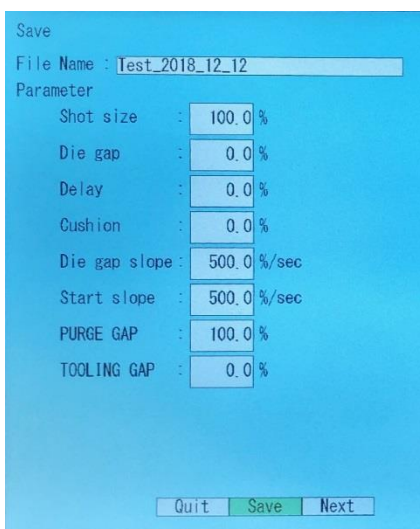

Figure 2-22 File Description
Data-Page 1

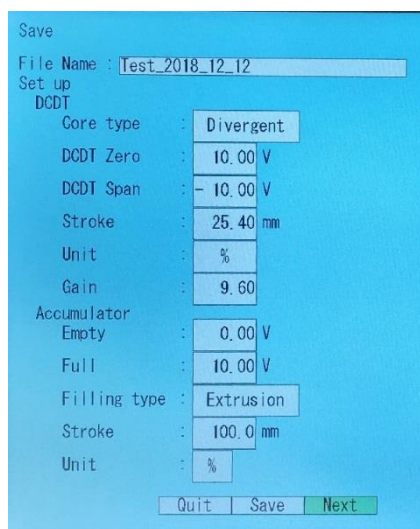

Figure 2-23 File Description
Data-Page 2

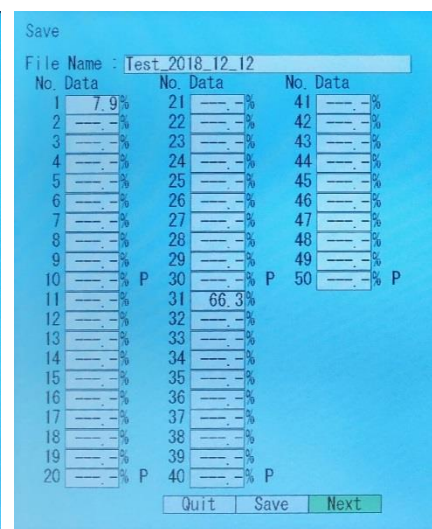

Figure 2-24 File Description
Data-Page 3

“Please edit file name Yes/No”

If you select “Yes” follow the instructions below....

The LCD display changes to the Edit screen (Figure 2-25) and prompts ‘File name’. Use the **Rotary Knob** or **directly touch** to input the name of file (32 characters maximum). The **Rotary Knob** moves the display cursor from character to character. The **SET** Key enters the individual characters of the file name.

Special Characters

The “←” and “→” symbols are used to move the display cursor within the file name.

The last character in the list inserts a blank space in the name.

The “END” character is necessary for entry completion. “END” must be inserted at the end of editing or the new file will not be renamed. (If not change the name, skip to Figure 2-22)

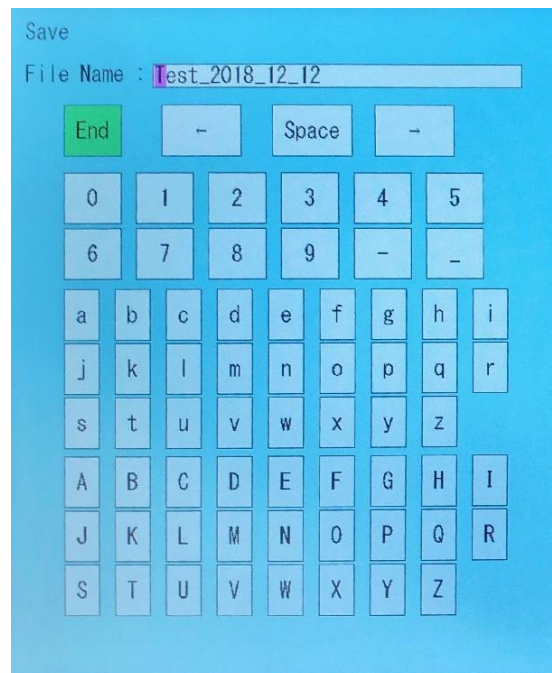

Figure 2-25 Edit File name

The LCD display changes to the File No. select screen (Figure 2-26) and prompts ‘File No.’ Move to the desired file number by using the **Rotary Knob** (selects in increments of 1) and the **Cursor** Key (selects in increments of 20). Press **SET** to enter. Or touch specified number frame, specify the desired file number, and press [SET].

After select file number, the LCD display changes to a description of the entry data (Figure 2-22, Figure 2-23, Figure 2-24) with the “Quit or Save or Next” prompt displayed. If you select “Save”, the DigiPackIII saves the data and displays file name in **F1 Profile** Mode. If you select “Quit”, you are returned to the first screen of the **F3 File** Mode and no data is saved.



If another data is already stored in the location of the specified file number, the data is saved in that location. In that case, previously saved data will be lost.

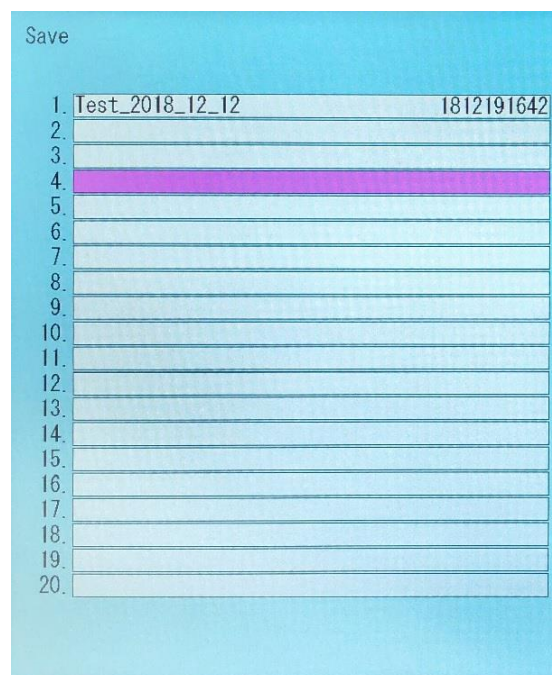

Figure 2-26 Change File Number

Load or Load SD

If you select “**Load or Load USB**” (Figure 2-20). The file list is displayed, starting at “**No. 0 Initial file**” (Figure 2-27). In this mode, files 0 to 100 are displayed in blocks of 5. You can find the required file by using the **Rotary Knob** (the display cursor moves through the files in order) and the **Cursor** (jumps files in blocks of 20) to find the desired file. Then press the **SET** Key. or Touch the file you need directly and press the [SET] key.

Figure 2-28 is displayed at the bottom of the LCD display. Select “**Quit**” or “**Load**” or “**Next**” with the **Rotary Knob** and **SET** Key or touch the item directly.

If “**Load**” is selected the file loads and is displayed in **F1 Profile Mode**. If you select “**Quit**”, the initial **F3 File Mode**, Figure 2-20, screen is displayed and no file is loaded.

If “**Next**” is selected, described other parameters.

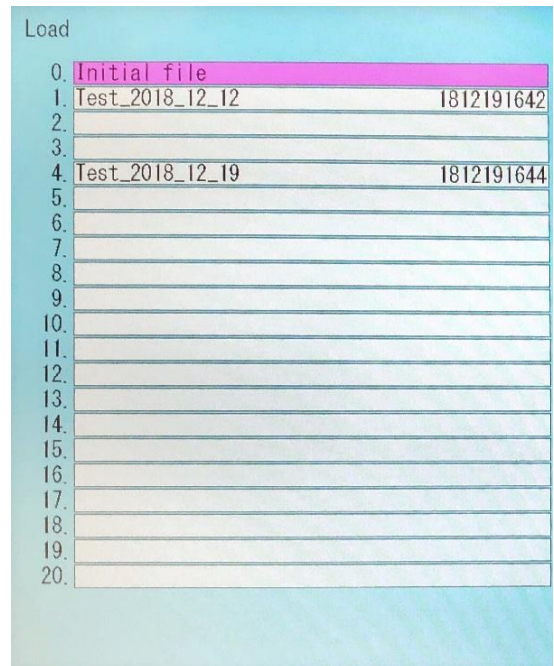



Figure 2-27 Initial Load Screen

 Setup data (for example GAIN, DCDT Zero/Span, etc.) will be loaded only for reference because of the machine safety.

Initialize data

For the initialization method, select "0. INITIAL FILE" and execute [Load]. As a result, all parameters return to their initial values (factory-set values).

※ Machine setting parameters are not changed.

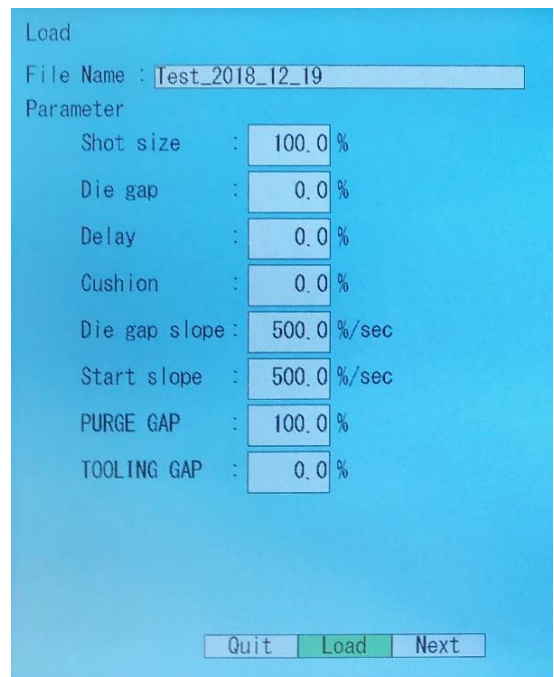

Figure 2-28 File Load

2-4-5. F4: Monitor Mode

Mode obtained by pressing the **F4** key.

Display

Available at all times. But not available to change manual mode when profile is running.

Manual Mode is used to display and/or control the positions of the tooling actuator (DCDT) and the value of the servovalve input current as well as the Output ON/OFF functions. Auto Mode ONLY displays the above information.

Commands

The **Cursor** is used (or directly touch) to move to the various commands only in MANUAL mode. The SET Key is inactive. The displayed values reflect the actual positions or servovalve current. (or Spool position in EFB mode)

Output

There are 6 output commands which may be changed with the **Rotaly Knob**. Counter-clockwise rotation produces a 0 (OFF) and Clockwise rotation a 1 (ON).

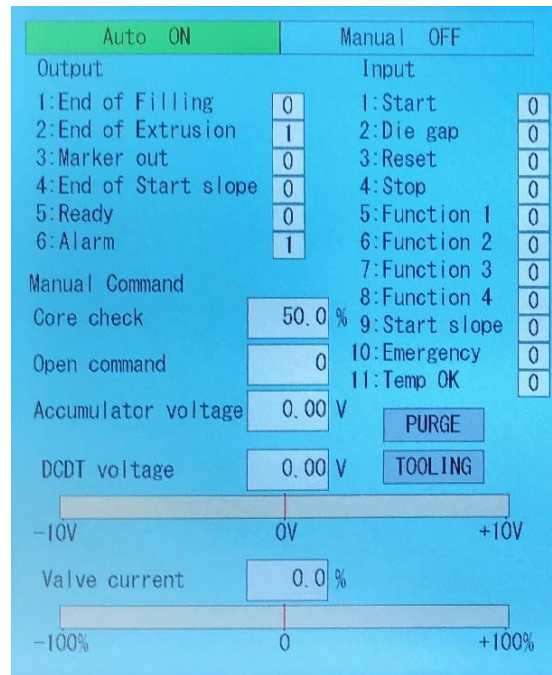

Figure 2-29 F4: Monito screen

The functions controlled are: (1) End of Filling; (2) End of Extrusion; (3) Point out; (4) End of Start slope; (5) Ready; (6) Alarm.

Input

There are 7 input commands to monitoring the following functions: (1) Start, (2) Die gap; (3) Reset; (4) Stop; (9) Start Slope, (10) Emergency, (11) Temp OK. (not use 5 to 8)

Core check

When the display **Cursor** points to “**Core check**”, it is possible to control the tooling position in closed loop using the **Rotaly Knob** between 0 to over 3276.7%. (100% = Span position) *This parameter can not be changed with 10 key.

Open command

When the display **Cursor** points to “**Open command**”, it is possible to control the value of the servovalve input current with the **Rotaly Knob**. *This parameter can not be changed with 10 key.



USE OF “Open command” MAY RESULT IN DAMAGE TO THE TOOLING.

When the servovalve input is equal to any value other than those in the Zero range, servovalve oil flow will cause the tooling cylinder to move. The tooling actuator will stop only when the servovalve input current is within a very narrow band in the Zero current range. If the tooling actuator stops due to contact with the die and mandrel, very high forces may be exerted on the tooling, possibly causing damage. It is highly recommended that the hydraulic pressure be reduced to a low value to prevent possible damage.

To prevent inadvertent damage, setting the Open command to “Disable” in Machine setup display ([SHIFT]→[F4]) will disable this function.

PURGE

With this switch, the core moves to the position set by the movement target position "PURGE GAP (F2 screen)".

By switching to the manual mode, the PURGE switch becomes effective (background white). When it is disabled, it becomes a gray background. In addition, the switch turns yellow while moving to the purge position.

TOOLING

With this switch, the core moves to the position set by the movement target position "TOOLING GAP (F2 screen)".

By switching to the manual mode, the TOOLING switch becomes effective (background white). When it is disabled, it becomes a gray background. In addition, the switch turns yellow while moving to the tooling position.

- * PURGE / TOOLING is the core forced opening and closing function. This function is effective when replacing resin or when performing initial setting (zero-span) of the accumulator.
- * The speed of the core moved by the PURGE / TOOLING switch is the speed set by "Die gap slope".
- * Refer to Section 1.9.3.3 Accumulator setup for the purge / tooling function during accumulator setting.

2-4-6. F5: Data Display Mode

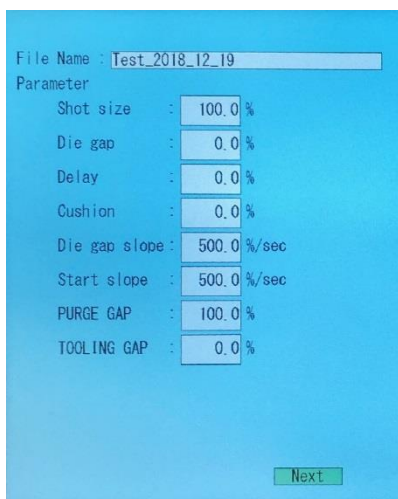

Figure 2-30 Data Display Screen A

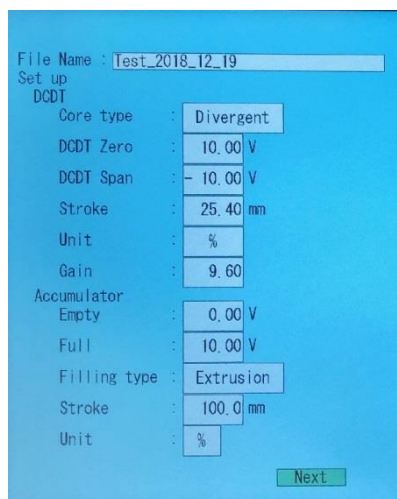

Figure 2-31 Data Display Screen B

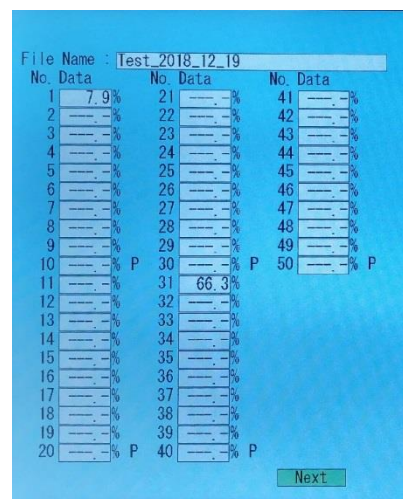

Figure 2-32 Data Display Screen C

Mode is displayed by pushing the **F5** Key

Display

Available when manufacturing containers.

Function

To display the conditions, parameters and profile data for the container currently being made. Select to "Next" see other page one by one. This screen mode is display only, parameter editing is not possible.

2-4-7. SHIFT→F1: Set Up Mode

The mode to shift by pressing [SHIFT] and pressing the [F1] key with the [SHIFT] key active.

Display

Not available when manufacturing containers. And Production can not be started while this screen is displayed.

Function

Set Up is used to set up the conditions and parameters required for proper operation when the container and/or die gap tooling are changed.

Commands

Set Up Mode is covered in detail in the DigiPackIII Installation manual at 1-9-3. SET UP PROCEDURE.

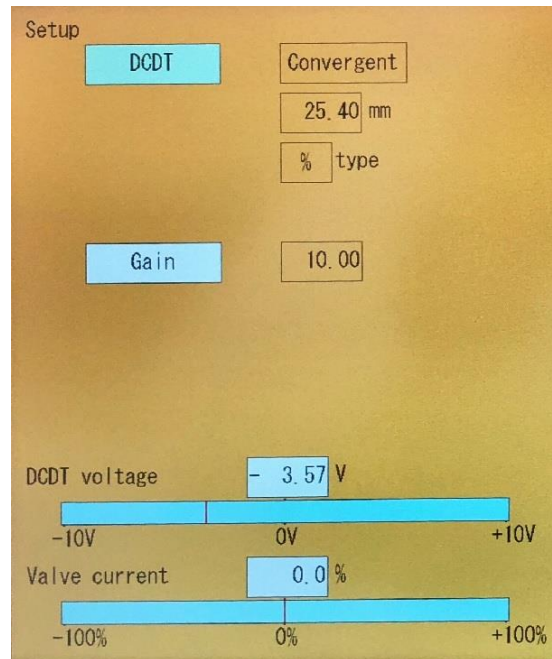

Figure 2-33 [SHIFT]→[F1]: Setup Screen

2-4-8. SHIFT→F2: Analog monitor

The mode to shift by pressing [SHIFT] and pressing the [F2] key with the [SHIFT] key active.

Display

Not Available while manufacturing containers. And Production can not be started while this screen is displayed.

Function

Internal signal assign to analog monitor channels 1 to 4. (TB1, 11, 12, 28 and 29). See 1-6-3. for details.

Commands

Change the displayed parameter using the SET Key or directly touch the parameter, revise the value with the **Entry Knob (or ten key)** and confirm with the **SET Key**.

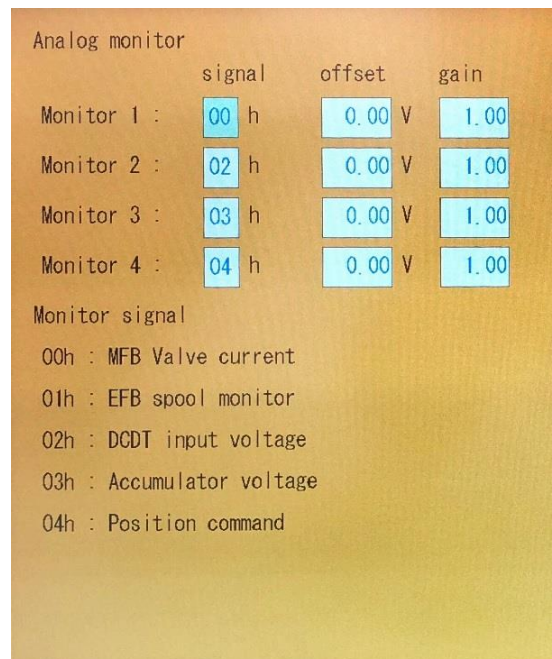

Figure 2-34 [SHIFT]→[F2]: Analog Monitor Screen

Signal

The following signals can be set in "signal". After that, each channel is monitored by the monitoring channel on TB1.

- 00h : MFB valve current -> Monitored MFB Servovalve Current (Set at SHIT→F4) with +-10V.
- 01h : EFB spool monitor -> Monitored Spool position (4-20mA) with +-10V if EFB mode.
- 02h : DCDT input voltage -> Monitored DCDT Position (0-100%) with 0-10V.

03h : Accumulator voltage -> Monitored Accumulator Position (0-100%) with 0-10V.
 04h : Position command -> Monitored Parison command signal with 0-10V.

Offset

Add this value to output signal of monitor channel.

Gain

Set gain function for output signal. Ex) if Gain=2.00 then 50% is 10V output.

2-4-9. SHIFT→F3: File delete and Backup/Restore

The mode to shift by pressing [SHIFT] and pressing the [F3] key with the [SHIFT] key active.

Display

Not Available while manufacturing containers. And Production can not be started while this screen is displayed.

Function

Data file delete and all data backup to USB Memory and Restore from USB Memory

Commands

Select the required function “Delete”, “Backup” or “Restore” using the **Entry Knob** and confirm with the **SET** Key or directly touch to the desired command.

Delete

Delete the existing file which saved in Flash RAM. (F3: File mode). If select the “Delete”, Display indicate as Figure 2-36. And select file name using **Rotaly Knob or touch** then press **SET**. It will be delete the selected file.



Figure 2-35 [SHIFT]→[F3]: File delete and Backup

Backup

If Select “Backup”, all Flash RAM data in DigiPackIII is copied in to USB Memory.

Restore

If Select “Restore”, all backup file in USB Memory restore to Flash RAM of DigiPackIII.

NOTE: [Backup] / [Restore] does not include executing files. Only files saved in F3 are covered.



When execute the Restore, all Flash RAM data in DigiPackIII are erased and write again data from USB Memory. If the save data in Flash RAM is different from USB Memory, all data in Flash RAM will lost.

And When the Backup or Restore executed, USB Memory needs to insert USB slot. If USB Memory is not in slot, below message occurred and can not continue Backup/Restore.

“ USB is not insert or format is not correct ”

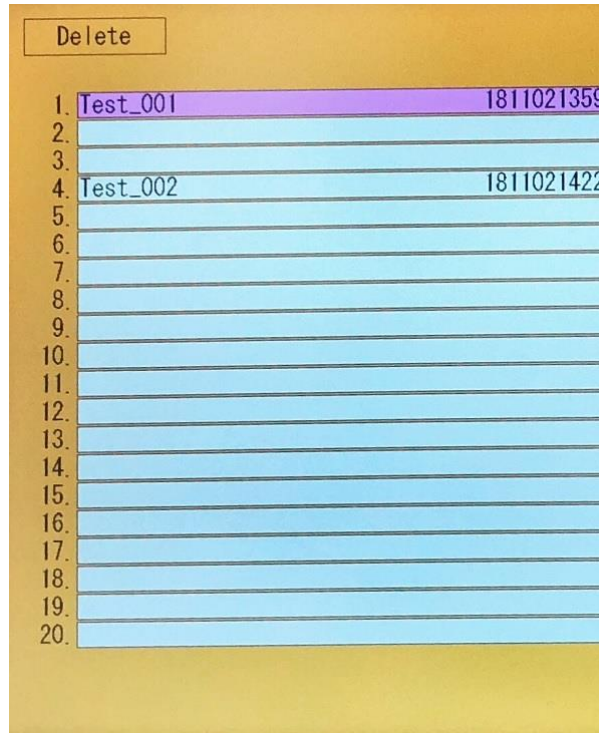

Figure 2-36 File Delete

2-4-10. SHIFT→F4: Machine Setup

The mode to shift by pressing [SHIFT] and pressing the [F4] key with the [SHIFT] key active.

Display

Not available when manufacturing containers. And Production can not be started while this screen is displayed.

Function

Machine setup is used to set up the conditions and parameters required for proper operation when install the **most beginning** to machine or change machine mode.

Commands

Machine setup is covered in detail in the DigiPackIII Installation manual at 1.9.2.1 Machine settings.

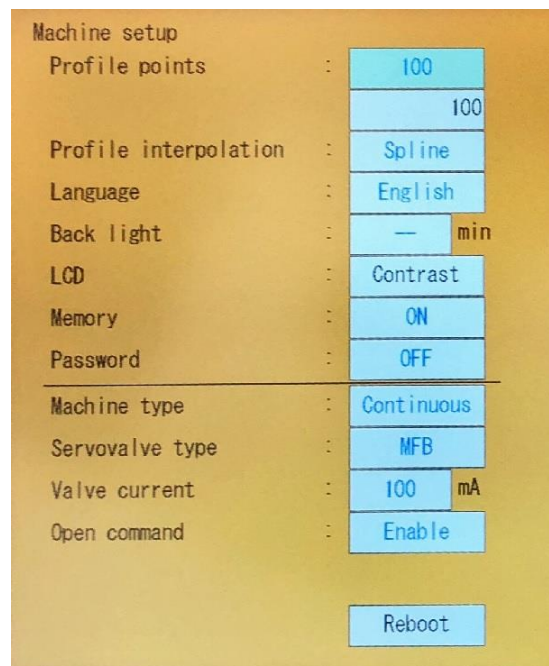

Figure 2-37 [SHIFT]→[F4]: Machine Setup Screen

2-4-11. SHIFT→F5: Communication Mode

The mode to shift by pressing [SHIFT] and pressing the [F4] key with the [SHIFT] key active.

Display

Not available when manufacturing containers.

Function

Provides RS422 and Ethernet communication with a host computer, using the parameters shown on the LCD display. And also can be set internal clock in this display.

Ethernet Communication Setup

DHCP	ON or OFF
IP address	If DHCP is ON, automatically set this parameter.
Net mask	If DHCP is ON, automatically set this parameter.
Gate way	If DHCP is ON, automatically set this parameter.
Port No.	0 – 65535

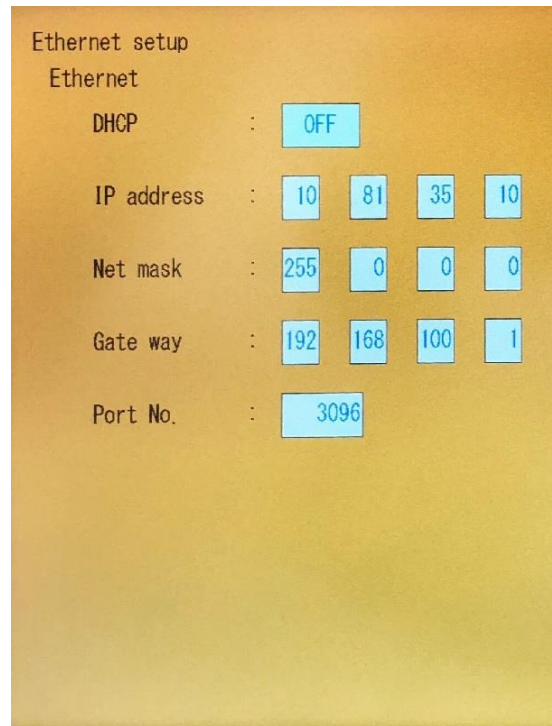

Figure 2-38 [SHIFT]→[F5]: Communication Mode Screen

2-5. COMMUNICATION PROTOCOL

2-5-1. EtherNET COMMUNICATION SPECIFICATION

Type	TCP/IP (EtherNET)
Communication character	ASCII code 20h~7Fh (Capital letter and control code)
	[STX](02h)、[ETX](03h)
	Numerical data is 2 and 4, 8 characters of hexadecimal number
	Capital letter (A,B,C,D,E,F)
Maximum packet length	Data: 1024[Byte] + control: 2[Byte]
Endianness	Big endian

Packet

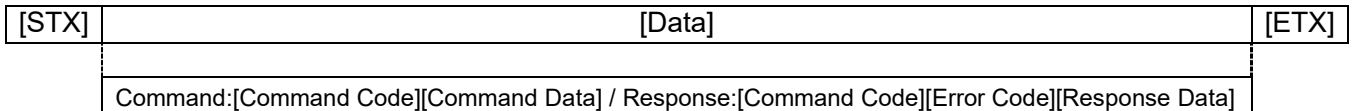

[STX] --- Single-byte character of ASCII code 02h. Represents the start of a packet.

[ETX] --- Single-byte character of ASCII code 03h. Represents the end of a packet.

[Command Code] --- 2-byte character string from the head of [data] used for command classification.

For details [Command data][Error code][response data], see the next section.

2-5-2. PROFILE

Please refer to the 2-6. profile data list.

2.5.2.1. WRITE PROFILE DATA (ALL PROFILE POINT)

PC→DigiPackIII	0	1	2	3	4	5	6	7	8	9	10	11	12	13	14	15	796	797	798	799	800	801	802	803	
	P	0	file No		Profile point 1				Profile point 2									...				Profile point 199				Profile point 200			

DigiPackIII→PC	0	1	2	3																												
	P	0	Error		file No 0 = F1 Screen profile data				file No 1~100 = F3 file (internal profile data)								Nothing Profile data "FFFF"															

2.5.2.2. READ PROFILE DATA (ALL PROFILE POINT)

PC→DigiPackIII	0	1	2	3																												
	P	1	file No														Nothing Profile data "FFFF"															

DigiPackIII→PC	0	1	2	3	4	5	6	7	8	9	10	11	12	13	14	15	796	797	798	799	800	801	802	803
	P	1	Error		Profile point 1				Profile point 2				Profile point 3				...				Profile point 199				Profile point 200			

2.5.2.3. WRITE PROFILE DATA (EACH DATA OR BLOCK DATA)

PC→DigiPackIII	0	1	2	3	4	5	6	7	8	9	10	11	12	13	14	15																
	P	2	file No		P-addr				Data				...								P-addr : Refer to Section 2-6											

DigiPackIII→PC	0	1	2	3																												
	P	2	Error																													

2.5.2.4. READ PROFILE DATA (EACH DATA OR BLOCK DATA)

PC→DigiPackIII	0	1	2	3	4	5	6	7	8	9																						
	P	3	file No		P-addr				n												"n" can be omitted, in that case 1											

DigiPackIII→PC	0	1	2	3	4	5	6	7	8	9	10	11																				
	P	3	Error		Data				...																							

2.5.2.5. WRITE ALL PROFILE DATA (INCLUDE PARAMETER)

PC→DigiPack III	0 1 2 3 P 4 file No	4 5 6 7 8 9 10 11 12 13 14 15 16 17 ... 35	File name length is fixed at 32 characters Fill in margins with spaces Space = 20h
		36 37 38 39 40 41 42 43 44 45 46 47 48 49 50 51 52 y y / m m / d d h h : m m : s s 53 54 55 56 ... 849 850 851 852 853 854 855 856 ... 889 890 891 892	
		Profile point 1 Profile point xx Profile point 200 Marker point 1 Marker point x Marker point 10 893 894 895 896 897 898 899 900 901 902 903 904 905 906 907 908 909 910 911 912 913 914 915 916	
		Shot size Die gap Delay Cushion Die gap slope Start slope 917 918 919 920 921 922 923 924 925 926 927 928 929 930 931 932 933 934 935 936 937 938 939 940	
		Spline Core stroke Accum. stroke DCDT Zero DCDT Span Accum. Empty 941 942 943 944 945 946 947 948 949 950 951 952 953 954 955 956 957 958 959 960	
		Accum. Full Type set Gain PURGE gap TOOLING gap	

DigiPack III→PC	0 1 2 3 P 4 Error	Nothing Profile data "FFFF" An error occurs if there is a file with the same name as another file number
-----------------	----------------------	---

2.5.2.6. READ ALL PROFILE DATA (INCLUDE PARAMETER)

PC→DigiPack III	0 1 2 3 P 5 file No		
DigiPack III→PC	0 1 2 3 P 5 Error	4 5 6 7 8 9 10 11 12 13 14 15 16 17 ... 35	File name length is fixed at 32 characters Fill in margins with spaces Space = 20h
		36 37 38 39 40 41 42 43 44 45 46 47 48 49 50 51 52 y y / m m / d d h h : m m : s s 53 54 55 56 ... 849 850 851 852 853 854 855 856 ... 889 890 891 892	
		Profile point 1 Profile point xx Profile point 200 Marker point 1 Marker point x Marker point 10 893 894 895 896 897 898 899 900 901 902 903 904 905 906 907 908 909 910 911 912 913 914 915 916	
		Shot size Die gap Delay Cushion Die gap slope Start slope 917 918 919 920 921 922 923 924 925 926 927 928 929 930 931 932 933 934 935 936 937 938 939 940	
		Spline Core stroke Accum. stroke DCDT Zero DCDT Span Accum. Empty 941 942 943 944 945 946 947 948 949 950 951 952 953 954 955 956	
		Accum. Full Type set Gain PURGE gap TOOLING gap	

Nothing Profile data "FFFF"

2.5.2.7. WRITE FILE NAME

PC→DigiPack III	0 1 2 3 P 6 file No	4 5 6 7 8 9 10 11 12 13 14 15 16 17 ... 35	File name length is fixed at 32 characters Fill in margins with spaces Space = 20h
		File name	

DigiPack III→PC	0 1 2 3 P 6 Error	Error, accessing unregistered file An error occurs if there is a file with the same name as another file number
-----------------	----------------------	--

2.5.2.8. READ FILE NAME

PC→DigiPack III	0 1 2 3 P 7 file No		File name length is fixed at 32 characters Fill in margins with spaces Space = 20h
DigiPack III→PC	0 1 2 3 P 7 Error	4 5 6 7 8 9 10 11 12 13 14 15 16 17 ... 35	Error, accessing unregistered file
		File name	

2.5.2.9. WRITE TIME

PC→DigiPack III	0 1 2 3 P 8 file No	4 5 6 7 8 9 10 11 12 13 14 15 16 17 18 19 20	Date and time data are handled in decimal character string Error, accessing unregistered file
		Year Month Day Hour Minits Sec y y / m m / d d h h : m m : s s	

DigiPack III→PC	0 1 2 3 P 8 Error	
-----------------	----------------------	--

2.5.2.10. READ TIME

PC→DigiPack III	0 1 2 3 P 9 file No		
DigiPack III→PC	0 1 2 3 P 9 Error	4 5 6 7 8 9 10 11 12 13 14 15 16 17 18 19 20	Date and time data are handled in decimal character string Error, accessing unregistered file
		y y / m m / d d h h : m m : s s	

2-5-3. WAVE

2.5.3.1. READ WAVE. WAVE MEMORY OF REAL OPERATION

PC→DigiPackIII

0	1	2	3	4	5	6	7	
T	0	Address					n	

Address : 0~495
 "n" : max 255
 "n" can be omitted, in that case 1
 The memory unset point is set to "FFFF"

DigiPackIII→PC

0	1	2	3	4	5	6	7	8	9	10	11	12	13	14	15
T	0	Error	Data1				Data2				...				

2-5-4. MONITOR

2.5.4.1. A/D CONVERT CHANNEL

PC→DigiPackIII

0	1	2	3	4	5
M	0	ch	n		

ch : the ADC channel number
 "n" can be omitted, in that case 1

DigiPackIII→PC

0	1	2	3	4	5	6	7	8	9	10	11	12	13	14	15
M	0	Error	Data1				Data2				...				

For channels from "ch" to "n"
 "ch" see 2-5-9. AD / DA list

2.5.4.2. D/A CONVERT CHANNEL

PC→DigiPackIII

0	1	2	3	4	5
M	1	ch	n		

ch : the DAC channel number
 "n" can be omitted, in that case 1

DigiPackIII→PC

0	1	2	3	4	5	6	7	8	9	10	11	12	13	14	15
M	1	Error	Data1				Data2				...				

For channels from "ch" to "n"
 "ch" see 2-5-9. AD / DA list

2.5.4.3. DIGITAL INPUT

PC→DigiPackIII

0	1	2	3	4	5
M	2	0	0	n	

"n" can be omitted, in that case 1

DigiPackIII→PC

0	1	2	3	4	5	6	7
M	2	Error	Data1				

"n" is the number
 For the configuration of Data1, see 2.5.6 Interface Control Reference

2.5.4.4. DIGITAL OUTPUT

PC→DigiPackIII

0	1	2	3	4	5
M	3	0	0	n	

"n" can be omitted, in that case 1

DigiPackIII→PC

0	1	2	3	4	5	6	7
M	3	Error	Data1				

"n" is the number
 For the configuration of Data1, see 2.5.6 Interface Control Reference

2-5-5. INFORMATION DATA

2.5.5.1. DEVICE NAME

PC→DigiPackIII

0	1	2	3
L	S	0	0

DigiPackIII→PC

0	1	2	3	4	5	6	7	8	9	10	11	12	13	14
L	S	Error	D	I	G	I		P	A	C	K			3

Variable length character data

2.5.5.2. SERIAL NUMBER

PC→DigiPackIII

0	1	2	3
L	S	0	1

DigiPackIII→PC

0	1	2	3	4	5	6
L	S	Error	1	2	3	

Variable length character data

2.5.5.3. PRODUCTION DATA

PC→DigiPackIII

0	1	2	3
L	S	0	2

DigiPackIII→PC

0	1	2	3	4	5	6	7	8	9	10	11
L	S	Error	2	0	1	0	/	4	/	1	

Variable length character data

2.5.5.4. HARDWARE VERSION

PC→DigiPackIII

0	1	2	3
L	S	0	3

DigiPackIII→PC

0	1	2	3	4	5	6	7
L	S	Error	V	1	.	0	

Variable length character data

2.5.5.5. SOFTWARE VERSION

PC→DigiPackIII

0	1	2	3
L	S	0	4

DigiPackIII→PC

0	1	2	3	4	5	6	7
L	S	Error	V	1	.	0	

Variable length character data

2.5.5.6. MAC ADDRESS

PC→DigiPackIII

0	1	2	3
L	S	1	0

DigiPackIII→PC

0	1	2	3	4	5	6	7	8	9	10	11	12	13	14	15	16	17	18	19	20	
L	S	Error	0	0	:	0	9	:	C	C	:	1	0	:	x	x	:	x	x		

Character data

2-5-6. INTERFACE CONTROL

2.5.6.1. ACQUIRING INTERFACE DATA

PC→DigiPackIII

0	1
I	G

※Interface data: 32 bit hexadecimal number

※Refer to Section 2.5.6.3 for the composition of interface data

DigiPackIII→PC

0	1	2	3	4	5	6	7	8	9	10	11
I	G	Error	Data								

2.5.6.2. INTERFACE DATA SETTING

PC→DigiPackIII

0	1	2	3	4	5	6	7	8	9
I	S	Data							

DigiPackIII→PC

0	1	2	3
I	S	Error	

※Interface data: 32 bit hexadecimal number

※Refer to Section 2.5.6.3 for the composition of interface data

2.5.6.3. INTERFACE DATA STRUCTURE (32 bits)

31	30	29	28	27	26	25	24	23	22	21	20	19	18	17	16	15	14	13	12	11	10	9	8	7	6	5	4	3	2	1	0
Communication virtual input pattern (10bits)											Actual digital Input pattern (10bits, only acquisition possible)											Actual digital Output pattern (10bits, only acquisition possible)									

↑ ↑
 ↑ Communication virtual input function 0 ... invalid / 1 ... Valid
 Digital output mode 0 ... AUTO / 1 ... MANUAL ※ Setting on the F4 Monitor screen (Acquisition only possible) ※Writing to bits that can only be acquired is ignored.

Communication virtual & actual digital input pattern 0 ... open / 1 ... Close	
bit 9	E-Stop Signal input
bit 8	Start slope Signal input
bit 7	(No assignment)
bit 6	(No assignment)
bit 5	(No assignment)
bit 4	Temp-OK Signal input
bit 3	Stop Signal input
bit 2	Reset Signal input (Do not reset by communication setting)
bit 1	Die gap Signal input
bit 0	Start Signal input

Actual digital output pattern 0 ... open / 1 ... Close	
bit 9	End of extrusion Relay status
bit 8	End of filling Relay status
bit 7	End of extrusion Signal output
bit 6	End of filling 信号出力
bit 5	(No assignment)
bit 4	Alarm Signal output
bit 3	Ready Signal output
bit 2	End of Start slope Signal output
bit 1	(No assignment)
bit 0	Maker out Signal output



Actual digital I/O is the state of the rear terminal block. When the communication virtual input function is invalid, the communication virtual input pattern is ignored and it operates only with the actual digital input. When the communication virtual input function is enabled, it is the logical sum (OR) of the close state between the communication virtual input and the actual digital input. Please note that it will be recognized as closed if either one is closed.

2.5.6.4. INTERFACE DATA SETTING (Edge setting)

PC→DigiPackIII	0	1	2	3
	I	X		bit

DigiPackIII→PC	0	1	2	3
	I	X		Error

bit ... 2 Hexadecimal digits. Specify the operation target bit with 00 to 09. Bits other than the operation target bit do not change. The number is as shown in the table of input in 2.5.6.3.

This “IX” command enables the communication virtual input function and indirectly manipulates the bit. After edge operation, the bit for communication virtual input is set to 0.

※The operation when an “IS” command or “IX” command is executed on the same bit within 2 [ms] after edge setting with the “IX” command is undefined.

To set them consecutively, leave at least 2 [msec] interval. (It is not necessary when manipulating another bit with the “IX” command.)

2.5.6.5. INTERFACE DATA SETTING (Level setting)

PC→DigiPackIII	0	1	2	3	4	5
	I	X		bit		Level

DigiPackIII→PC	0	1	2	3
	I	X		Error

bit ... 2 Hexadecimal digits. Specify the operation target bit with 00 to 09. Bits other than the operation target bit do not change. The number is as shown in the table of input in 2.5.6.3.

Level ... 2 hexadecimal digits. 00 = Open, Other than 00 = Closed.

2-5-7. OTHER

2.5.7.1. RESET COMMAND

0	1	2	3
R	S	0	0

PC→DigiPackIII

0	1	2	3
R	S	Error	

DigiPackIII→PC

2.5.7.2. SET RTC

0	1	2	3	4	5	6	7	8	9	10	11	12	13	14	15	16	17	18	19	20
R	T	0	0	y	y	/	m	m	/	d	d		h	h	:	m	m	:	s	s

PC→DigiPackIII

Set RTC.
It is reflected at the time of transmission.

0	1	2	3
R	T	Error	

DigiPackIII→PC

Error of time format error becomes "data value range error".

2.5.7.3. GET RTC

0	1	2	3
R	T	0	1

PC→DigiPackIII

0	1	2	3	4	5	6	7	8	9	10	11	12	13	14	15	16	17	18	19	20
R	T	Error	y	y	/	m	m	/	d	d		h	h	:	m	m	:	s	s	

DigiPackIII→PC

2-5-8. ERROR CODE

0	No Error	Successful completion
1	Command Code Error	Corresponding command code does not exist
2	Command Length Error	The command is not in the specified format
3	Numeric string error	Number specification or data value is not a correct numeric string (hexadecimal / decimal)
4	Number specification error	Value other than specified value for number specification
5	Data value range error	Data value is outside the specified range
6	No File Error	Accessed an unregistered file
10	Flash memory Error	Failed to write to Flash memory

Command part of ※ 1
Overall length of ※ 1
Number and Data part of ※ 1
Number part of ※ 1
Data part of ※ 1

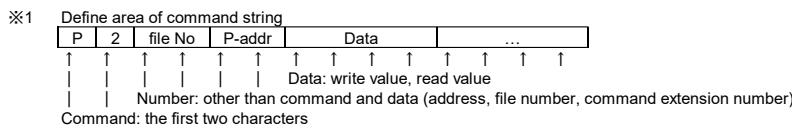

2-5-9. ADC/DAC CHANNEL

USE	AD/DA channel	IN/OUT Specification	Resolution
Core position voltage (DCDT)	ADC#0	-10V~10V	30802
EFB spool current	ADC#1	4~20mA、Center:12mA	26214
(Unimplemented)	ADC#2	—	—
Accumulator position voltage	ADC#3	0~10V	30802
(Unimplemented)	ADC#4	—	—
MFB current	ADC#5	-100~100mA	28836
2.5V A Internal voltage	ADC#6	Unused	—
2.5V B Internal voltage	ADC#7	Unused	—
0.0V A Internal voltage	ADC#8	Unused	—
0.0V B Internal voltage	ADC#9	Unused	—
Monitor 0~3 voltage	DAC#0~#3	-10V~10V	32767
EFB voltage	DAC#4-EFB Selected	-10V~10V	32767
MFB current	DAC#4-MFB 10mA Selected	-10mA~+10mA	32767
	DAC#4-MFB 20mA Selected	-20mA~+20mA	32767
	DAC#4-MFB 50mA Selected	-50mA~+50mA	32767
	DAC#4-MFB100mA Selected	-100mA~+100mA	32767

2-6. PROFILE DATA LIST

Profile Data address and data form

	address	name	range	screen	content
1		File no	1~100	[F3]	"0" is F1 screen profile data
2		File name		[F1],[F2],[F3],[F5]	max 32 characters
3		Date		[F3]	yy/mm/dd hh:mm:ss 17 characters
4	00	Shot size/Cycle time	1 ~ 9999	[F1]	Shot size[0.1%]/Cycle time[0.1sec]
5	01	Die gap	0 ~ 1000	[F1]	[0.1%]
6	02	Delay	0 ~ 9999	[F1]	[0.1%]
7	03	Cushion	0 ~ 9999	[F1]	[0.1%]
8	04	Die gap slope	1 ~ 9999	[F2]	[0.1%/sec]
9	05	Start slope	1 ~ 9999	[F2]	[0.1%/sec]
10	06	Spline	0=invalid 1=valid	[SHIFT]→[F4]	
11	07	Core stroke	1 ~ 9999	[SHIFT]→[F1]	unit 0.01mm Tooling length
12	08	Accum. stroke	1 ~ 9999	[SHIFT]→[F1]	unit 0.1mm
13	09	DCDT zero	-1000 ~ 1000	[SHIFT]→[F1]	set voltage : unit [0.01V]
14	0A	DCDT span	-1000 ~ 1000	[SHIFT]→[F1]	set voltage : unit [0.01V]
15	0B	Accum. Empty	0 ~ 1000	[SHIFT]→[F1]	set voltage : unit [0.01V]
16	0C	Accum. Full	0 ~ 1000	[SHIFT]→[F1]	set voltage : unit [0.01V]
17	0D	Type set	bit0: 0 = Divergent, 1= Convergent	[SHIFT]→[F1]	(Core type)
			bit1: 0 = %, 1 = mm		(Core stroke unit)
			bit2: 0 = %, 1 = mm		(Accumulator stroke unit)
			bit3: 0 = Extrusion fixed, 1 = Filling fixed		(Accumulator type only)
			bit4: 0 = OFF, 1 = ON		(Auto cycle)
18	0E	Gain	1~32767	[SHIFT]→[F1]	[0.01]
19	70	Marker point 1	0~200	[F2]	Profile point 1~200 ("0" is not output)
20	71	Marker point 2	0~200	[F2]	
21	72	Marker point 3	0~200	[F2]	
22	73	Marker point 4	0~200	[F2]	
23	74	Marker point 5	0~200	[F2]	
24	75	Marker point 6	0~200	[F2]	
25	76	Marker point 7	0~200	[F2]	
26	77	Marker point 8	0~200	[F2]	
27	78	Marker point 9	0~200	[F2]	
28	79	Marker point 10	0~200	[F2]	
29	80	Profile point 1	-1 ~ 1000	[F1]	[0.1%]
30	81	Profile point 2	-1 ~ 1000	[F1]	[0.1%]
?	?	?	?	?	?
228	147	Profile point 200	-1 ~ 1000	[F1]	[0.1%]
229	148	PURGE gap	0~1000	[F2]	[0.1%]
230	149	TOOLING gap	0~1000	[F2]	[0.1%]

2-7. SETTING UP

2-7-1. OBJECTIVE

The container produced by the blow molding process must meet the customer's specification. Customer's specifications normally involve standards for appearance, weight and physical characteristics such as strength, endurance and dimensional accuracy.

The container design process will determine the material to be used, the shape of the mold and required special features as well as the size and shape of the die gap tooling.

The task of the set up man is to use the above information with the DigiPackIII to control the parison wall thickness and placement in the mold to produce the container to its design specification.

The setup man must become familiar with the contents and definitions contained in Section 1-5.

2-7-2. DIE GAP TOOLING SETUP

A feature of the DigiPackIII is its ability to store the programmed parison wall thickness profile and other settings required to produce a particular container. Up to 100 container files may be stored. The stored container files in the DigiPackIII easily allow the change from one container to another. ※ USB memory is used for external data storage.

The stored information for a particular container contains the closed tooling die gap position and the relationship between the programmed wall thickness or die gap opening and the actual tooling die gap opening produced by the desired wall thickness. In other words, the relationship between the programmed die gap opening and the actual die gap opening has been calibrated. For example, a commanded die gap opening of 37% could be calibrated to cause an actual die gap opening of 6.7mm. The tooling die gap calibration information is contained in the container file.

In order to quickly change the blow molding machine production from one container to another with minimum change over time, the tooling die gap calibration must be accurately established.

The DigiPackIII Installation and Maintenance Manual contains a tooling die gap calibration procedure in Section 1-9-3. , DIE GAP TOOLING SETUP. To achieve the minimum change over time it is essential that this procedure be followed and the requested information recorded.

2-7-3. PRELIMINARY SET UP

SHOT SIZE

Shot Size basically determines the amount of plastic to be extruded through the die gap to make the container. In an accumulator machine it is the extrusion stroke of the accumulator, in a continuous machine it is determined by the time required to extrude the plastic volume or weight required by the container and tail, and also by the cooling capacity of the mold. This time or stroke was probably determined when the particular blow molding machine was selected to produce the container.

DIE GAP

Die Gap will probably be set to 0% for an accumulator machine to eliminate drool. In a continuous extrusion machine, the Die Gap must be used to set a minimum die gap opening (may also have mechanically set minimum opening) to prevent damage to the extruder and/or tooling due to excessive pressure or to a larger opening consistent with the parison tail requirements at the top of the container.

DELAY

Delay will initially be determined by the required tail length at the bottom of the container. Delay would be equal to the tail length divided by the length of the mold.

AUTO SHOT

Auto Shot does not apply to accumulator machines,.

Auto Shot would be ON if the DigiPackIII is only controlling the parison wall thickness and its cycle time is determined only by the interval between the machine controlled knife cuts.

Auto Shot would be OFF if the machine timing is partially or totally controlled by the DigiPackIII. For example, if the mold closure timing is controlled by a DigiPackIII marker pulse, then the time from the knife cut to mold closure is set by the DigiPackIII's Shot Size; the time from the marker pulse to the knife cut is controlled by the machine's controller.

WEIGHT, RANGE H and RANGE L

Weight, Range H and Range L are set by default to zero at the beginning of setup. These settings will be adjusted based on the actual molded product.

2-7-4. INITIAL TRIALS

After the heater bands have brought the extruder barrel and extrusion head to the desired temperature, some trial containers are blown. The blow molding machine timing and motions are adjusted to obtain a sealed container. Adjustments to the constant die gap program, **Shot Size, Die Gap** and **Delay** may have to be made before a sealed container is obtained. At this time, the die gap tooling opening is fixed and the operator would follow the same logic he would use if the tooling was mechanically fixed in position to obtain a sealed container.

Once a sealed container is obtained, it should be sliced open along the axis parallel to the parison length. If the containers plastic material is translucent, then thick and thin areas can be found by visual observation. In any case, container wall thickness measurements should be made along the cut edge and compared with the target wall thickness. The wall thickness or die gap opening program is then changed based upon the differences with the target thickness.

More containers are then blown, cut open and the die gap opening changed as required. After two or three trials it would be helpful to know the location of the programmed portion of the parison in the mold.

One method is to reduce the programmed thickness at one point and determine where that reduced wall thickness ring is located in the container wall. Often, the reduced thickness point can be clearly seen. Further trials with a single reduced thickness point at different locations along the container will help to determine the position of the programmed points along the length of the actual container.

Do not run tests with more than one reduced thickness point. Reducing the wall thickness at a point will change the distribution of plastic along the parison length and the use of more than one reduced thickness point will lead to improper assessment of the results.

A second method to determine the program point distribution on the container is to mark the parison wall at or as near as possible to the place where the parison leaves the die gap tooling. The marks may be applied manually or it may be possible to use marker pulses to operate an ink jet. This method marks the program points on the parison without distorting the parison or container.

When program points 1 and 200 are marked, the position of the programmed portion of the parison in the mold may be determined and adjusted.

A constant thickness container wall will be probably obtained before the correct weight. Adjustment of Weight, Range H or Range L will then allow both the correct container weight and wall thickness to be obtained with minimum requirement for the operator to change the value of any individual programmed die gap opening points.

++