

REVISIONS				
ZONE	REV.	DESCRIPTION	DATE	APPROVED
	A	NEW DRAWING/NTD 10183		

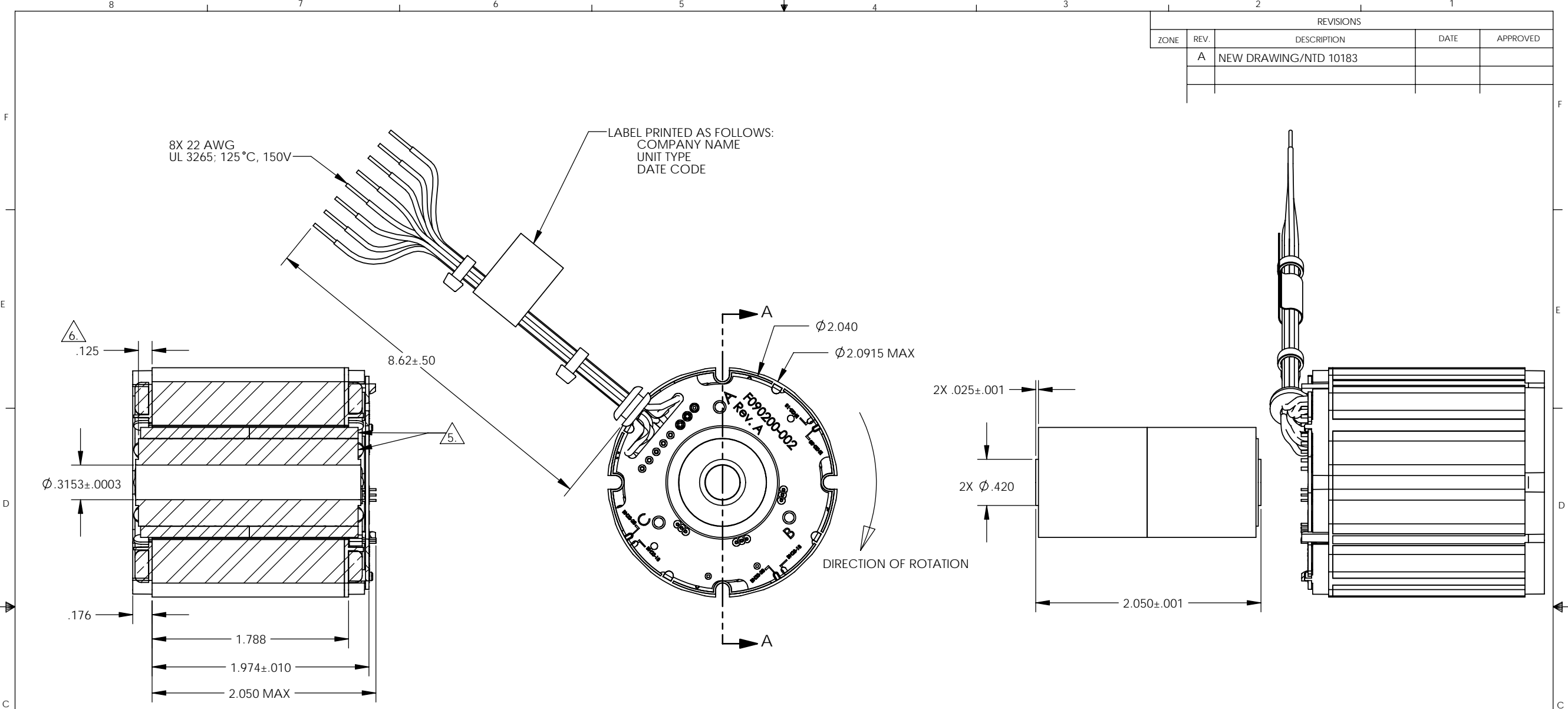

NOTES UNLESS OTHERWISE SPECIFIED:

1. INTERPRET DRAWING PER ASME Y14.100.
2. OPEN COLLECTOR OUTPUTS, USE PULL UP RESISTORS BETWEEN V_{CC} AND OUTPUTS.
3. TESTED AS A MOTOR ASSEMBLY MOUNTED TO 6" X 6" X 1/4" ALUMINUM PLATE, STILL AIR.
4. MAXIMUM WINDING TEMPERATURE OF 155°C.
5. MAGNET RING AND ROTOR CORE: FLUSH ±.002 ON THIS SIDE.
6. RECOMENDED ROTOR CORE TO STACK MOUNTING DIMENSION.

PERFORMANCE AT 25°C				
PARAMETER	SYMBOL	UNITS	TOLERANCE	VALUE
TERMINAL VOLTAGE	V	VOLTS DC	NOMINAL	48
PEAK TORQUE	T _P	OZ-IN	MAXIMUM	186
CONTINUOUS STALL TORQUE	T _C ¹	OZ-IN	MAXIMUM	53.2
NO LOAD SPEED	S _{NL}	RPM	NOMINAL	8100
RATED SPEED	S _R	RPM		6140
RATED TORQUE		OZ-IN	MAXIMUM	48.8
RATED CURRENT		AMPS		5.85
RATED POWER		WATTS		222
TORQUE SENSITIVITY	K _T	OZ-IN/AMP	±10%	7.80
BEMF CONSTANT	K _E	VOLTS/KRPM	±10%	5.77
TERMINAL RESISTANCE	R _M	OHMS	±12%	0.576
TERMINAL INDUCTANCE	L _M	mH	±30%	0.770
MOTOR CONSTANT	K _M	OZ-IN/√ WATTS	NOMINAL	10.28
SPEED TORQUE GRADIENT		RPM/OZ-IN		40
MECHANICAL TIME CONSTANT		msec		2.50
ELECTRICAL TIME CONSTANT		msec		1.34
THERMAL RESISTIVITY		°C/WATT		1.86

TERMINATION TABLE	
COLOR	CONNECTION
VIOLET	A COIL
BLACK	B COIL
GREEN	C COIL
YELLOW	V _{CC}
GREY	GROUND
BROWN	S1 OUT
BLUE	S2 OUT
WHITE	S3 OUT

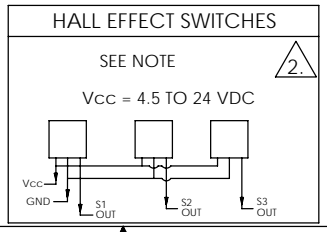
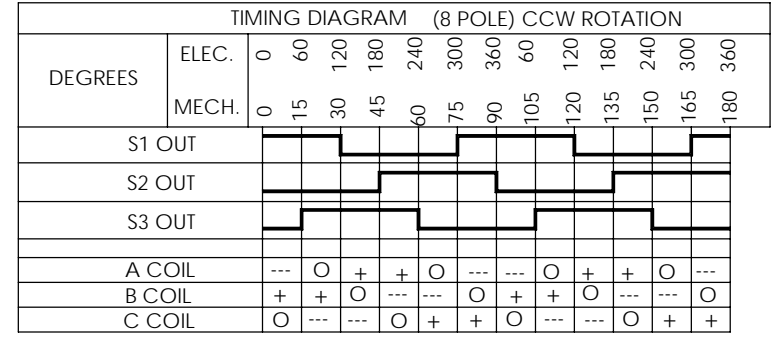

UNLESS OTHERWISE SPECIFIED DIMENSIONS ARE IN INCHES		CAD GENERATED DRAWING, DO NOT MANUALLY UPDATE			
TOLERANCES ARE:		APPROVALS			
DECIMALS ±.010	ANGLES ±0°30'	DRAWN R. PACE	DATE 1/31/06	BRUSHLESS D.C. MOTOR OUTLINE	
XXX ±.005	FRACTIONS ±1/64	CHECKED R. MARTIN	2/10/06		
XXXX ±.0005		ENGR D. THOMPSON	2/10/06		
		RELEASED R. MARTIN	2/14/06		
		MFG ENGR L. FORRISTER	2/13/06		
DO NOT SCALE DRAWING		SHOP ENGR		SIZE C	CAGE CODE 4H618
MATERIAL		QA B. LITTLE	2/10/06	SCALE 1.5:1	DWG NO. BN23-28ZMG-03LH
FINISH				CAD FILE BN23-28ZMG-03LH	SHEET 1 OF 1